



CD/DVD LIBRARY

BEDIENUGSANLEITUNG : CD/DVD BIBLIOTHEK

MANUEL D'INSTRUCTIONS : BIBLIOTHEQUE CD/DVD

使用说明书 : CD/DVD 光盘库

MC-8200LU MC-8600LU

INSTRUCTIONS

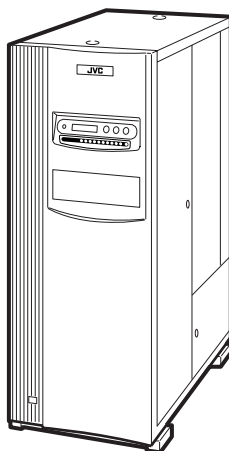

MC-8200LU

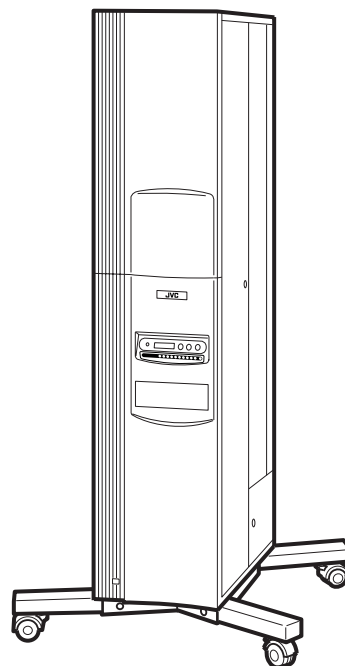

MC-8600LU

For Customer Use:

Enter below the Model No. and Serial No. which is located on the rear of the cabinet. Retain this information for future reference.

Model No. MC-8200LU / MC-8600LU

Serial No. _____

This instruction book is made from 100% recycled paper.

For Europe

IMPORTANT

The wires in this mains lead are coloured in accordance with the following code:



GREEN - and - YELLOW:	EARTH
BLUE:	NEUTRAL
BROWN:	LIVE

As the colours of the wires in the mains lead of this apparatus may not correspond with the coloured markings identifying the terminals in your plug, proceed as follows. The wire which is coloured GREEN-AND-YELLOW must be connected to the terminal in the plug which is marked with the letter E or the safety earth symbol  or coloured GREEN or GREEN-AND-YELLOW. The wire which is coloured BLUE must be connected to the terminal which is marked with the letter N or which is coloured BLACK. The wire which is coloured BROWN must be connected to the terminal which is marked with the letter L or coloured RED.

**WARNING—THIS APPARATUS
MUST BE EARTHED**

WARNING:

**TO PREVENT FIRE OR SHOCK HAZARD, DO NOT
EXPOSE THIS APPLIANCE TO RAIN OR MOISTURE.**

	CAUTION RISK OF ELECTRIC SHOCK DO NOT OPEN	
CAUTION: TO REDUCE THE RISK OF ELECTRIC SHOCK, DO NOT REMOVE COVER (OR BACK). NO USER-SERVICEABLE PARTS INSIDE. REFER SERVICING TO QUALIFIED SERVICE PERSONNEL		



The lightning flash with arrowhead symbol, within an equilateral triangle, is intended to alert the user to the presence of uninsulated "dangerous voltage" within the product's enclosure that may be of sufficient magnitude to constitute a risk of electric shock to persons.



The exclamation point within an equilateral triangle is intended to alert the user to the presence of important operating and maintenance (servicing) instructions in the literature accompanying the appliance.



Warning

This is a Class A product. In a domestic environment this product may cause radio interference in which case the user may be required to take adequate measures.

For North America

REPRODUCTION OF LABELS

CLASSIFICATION LABEL, PLACED ON
REAR ENCLOSURE.

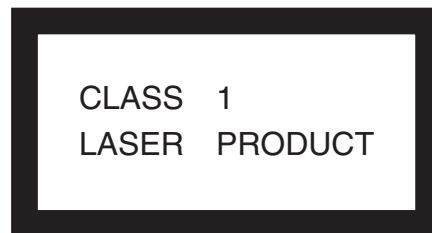

IMPORTANT FOR LASER PRODUCT

1. CLASS 1 LASER PRODUCT
2. **DANGER** : Invisible laser radiation when open and interlock failed or defeated. Avoid direct exposure to beam.
3. **CAUTION** : Do not open the top cover. There are no user serviceable parts inside the unit: leave all servicing to qualified service personnel.

CAUTION

Use of controls or adjustments or performance of procedures other than those specified herein may result in hazardous radiation exposure.

Information for Canada

This Class [A] digital apparatus complies with Canadian ICES-003.

Informations pour le Canada

Cet appareil numérique de la classe [A] est conforme à la norme NMB-003 du Canada.

Information for USA

NOTE: This equipment has been tested and found to comply with the limits for a Class A digital device, pursuant to Part 15 of the FCC Rules.

These limits are designed to provide reasonable protection against harmful interference when the equipment is operated in a commercial environment.

This equipment generates, uses, and can radiate radio frequency energy and, if not installed and used in accordance with the instruction manual, may cause harmful interference to radio communications. Operation of this equipment in a residential area is likely to cause harmful interference in which case the user will be required to correct the interference at his own expense.

Modifications not expressly approved by the manufacturer could void the user's authority to operate the equipment under FCC rules.

Note

Place a cover on the terminal when not in use. Static may cause a malfunction or failure of the unit.

Thank you for purchasing the JVC MC-8200LU/8600LU CD/DVD Library

Special Features

The MC-8200LU/8600LU CD/DVD Library is a highly reliable and durable disc changer equipped with large capacity and high access speed to cope with the ever-changing needs of the rapidly developing information network age. This model is suitable for business as well as home use.

- **Capacity**
Up to 600^{*1} optical discs^{*1} (12 cm discs) can be accommodated.
- **Double-sided disc compatibility**
Double-sided discs may also be accommodated, by adding an optional carrier^{*4}.
- **Six drive bay slots**
Six drive bay slots are provided so up to 6 drives^{*3} can be installed.
- **High-speed interface**
The LVD SCSI interface is adopted to enable a maximum external cable length of 10 meters as well as to increase the data transfer rate^{*5}.

^{*1} MC-8600U (200 discs with the MC-8200U).

^{*2} Media compatible with the library varies depending on the installed drive types. For details, refer to the instruction manuals of the relevant drives.

^{*3} For the compatible optional drives, see Specifications on page E34.

^{*4} MC-CF10U: Optional Carrier

^{*5} The data transfer rate is dependent on the installed drives. For details, refer to the instruction manual for the optional drives.

CAUTION

This product does not include drives. Optional drives should be purchased and installed before using the product. After installing, adding or replacing drives, be sure to execute the automatic drive detection mode as described on page E24. Malfunctions may occur if this procedure is not performed.

CAUTION

This equipment is supplied with an internal mechanism lock and protective materials. The lock should be opened and the protective materials removed before use.

Be sure to perform the unlocking and removal operations in accordance with the corresponding information in this manual. (→ Page E11, E12, E13)

CAUTION

The magazines and trays used with the MC-1000U/2000U series CD-ROM Library (MC-M15U) and MC-7000U series DVD-RAM (MC-M25U) are not compatible with those used with the MC-8000U/LU series CD/DVD Library. Do not interchange the magazines and trays between these models, as this will damage the equipment.

CAUTION

If a media that is not compatible with any of the installed drives is used in the library, malfunctions will result. To prevent this happening, be sure to check the instruction manuals of the optional drives in order to confirm that the media to be accommodated is compatible with the drive.

CAUTION

When using 6 of the MC-R434U units together, be sure that the room temperature is between 5 °C and 30 °C.

PACKAGED ITEMS

The following table shows the items provided in the package. Always check thoroughly that all the items are present when unpacking.

Item	Qty	MC-8200LU	MC-8600LU
Main unit	1	○	○
Door opening/closing keys	2	○	○
Main unit power cord (2.5 m)	2	○	○
Casters	4	—	○
Instructions (this manual)	1	○	○
Caster attaching procedure	1	—	○

CONTENTS

1. PRECAUTIONS	5
■ Installation and handling precautions	5
■ Disc handling precautions	5
2. NAMES AND FUNCTIONS OF PARTS	6
2-1. Front panel, right side panel, rear panel	6
2-2. Interior	7
2-3. Magazine numbers, tray numbers, disc numbers	8
2-4. Internal SCSI cable	8
2-4. Internal SCSI cable	9
3. SETUP	10
3-1. Attaching the casters	10
3-2. Opening the transport lock	11
3-3. Removing the transport protective materials	12
3-4. Removing the optional carrier transport lock screw	13
3-5. Installing drives and settings SCSI-ID No., etc.	13
3-6. Connecting the power cord and cables	14
4. CONTROL PANEL OPERATIONS AND LCD DISPLAY	15
4-1. Normal display	15
4-2. Menu display	15
4-3. Event display	16
4-4. Display and operation sequence	17
5. DOOR OPENING/CLOSING	18
6. MAIL SLOT	19
6-1. Disc loading	19
6-2. Import/export operation	20
7. DRIVE UNITS	22
7-4. Connecting the cables	22
7-5. Installing the panels	22
7-3. Setting the SCSI-ID Numbers, etc.	23
7-4. Connecting the cables	23
7-5. Installing the panels	24
7-6. Automatic drive detection mode	24
7-7. Drive type display	25
8. SETTING THE SCSI-ID NUMBERS OF THE MAIN UNIT	26
8-1. Display for checking the SCSI ID numbers	26
9. MAGAZINES	27
9-1. Ejecting/loading the magazines	27
9-3. Automatic disc checking function	28
9-3. Automatic disc checking function	29
10 ERROR CODES	30
10-1. Error code explanation	31
10-2. Error code list	31
10-3. How to cancel the Error "64"	31
10-4. Error history display	32
10-5. Troubleshooting	32
11. ACCESS COUNTS	33
SPECIFICATIONS	34

1. PRECAUTIONS

■ Installation and handling precautions

(1) Opening the transport lock

- Make sure that the transport lock is released and all transport protective materials are removed before turning on the power. Failure to do so will result in equipment malfunction.

(2) Location of installation

- Do not install the equipment near a source of vibration such as motor, engine or loudspeaker. They may adversely affect the equipment performance.
- Do not install the equipment in a place that is exposed to radiation, X-rays or corrosive gases. This may cause a malfunction or failure of the equipment.
- If the equipment is to have a fixed installation, we advise you to give sufficient allowance for space so that extension and replacement of optional units and other operations such as replacement and maintenance can be easily performed. For details, please consult your dealer or nearest JVC-authorized service agent.

(3) Condensation

- If the equipment which has been left in a cold room for a long period of time and is moved to a warm room or if the temperature of the room suddenly increases, condensation may occur on a mobile part, optical pickup or a disc inside the equipment with a disabling effect. If this occurs, do not use the equipment for a few hours before starting it again.

(4) Interference with reception of other devices

- When this equipment is used near a radio receiver such as a radio, television or BS tuner, reception of radio waves on these these devices may experience interference.

(5) Use in a strong radio wave environment

The equipment may not function properly if it is used in a strong radio wave environment, for example near an illegal radio station or a broadcasting station. If this happens, please consult your dealer or nearest JVC-authorized service agent.

(6) Compatible media

Media compatible with the MC-8200U/8600U varies depending on the drive in which it is accommodated. For details, refer to the instruction manual of the relevant drive.

(7) Installation environment

- This equipment has been designed with consideration for dust protection, but its structure is not dust-proof. Therefore, if it is used in an environment where cigarette smoke and/or dust are present, the lens of the drive or a disc will become dirty and stop functioning correctly. Using the equipment in these conditions should be avoided. If, however, you have to use it in a dusty environment, make sure to carry out 'maintenance & regular inspection' at an earlier interval.
- If the equipment is used outside of the suitable temperature and humidity range, the drive life may become greatly shortened. Please make sure to use the equipment in an appropriate environment.

(8) Backup

- JVC cannot accept responsibility for any loss of data and/or any other direct and indirect damage caused by the use or malfunctioning of this equipment. We therefore strongly advise that all important data should be fully backed up in case of unexpected loss.
- When this equipment is used with a system which runs continually for 24 hours or which cannot be turned off at all, we recommend a redundancy design such as [a] back-up system on the system.

(9) Never take the equipment apart.

- Fire and electric shock may result. Do not try to take apart or modify this equipment or the drive units inside.

(10) Cleaning

- Do not use solvents (paint thinner, benzene, etc.), cleaning products containing abrasives, anti-static agent, cloth soaked in detergent and silicon cloth. They can cause discoloration.
- Wipe-clean using a well-squeezed cloth which has been soaked in a neutral detergent.

(11) Do not place anything on the top panel.

- Do not place any objects on or step onto the top panel of this equipment as a malfunction or accident may result.

■ Disc handling precautions

A disc is made of plastic material which can be easily damaged. If the discs are damaged or become dirty, it may lead to malfunction such as incorrect data readout. To prevent this handle the discs with care so that they will stay free of damage, stain, dust/dirt adhesion, warping, etc.

(1) Do not touch the reflective surface (data surface) of a disc directly with your hand. Be sure to use special care when handling double-sided discs.

(2) Use commercially available cleaning kits such as a CD cleaner to remove dust and/or dirt from the disc surface.

- Gently wipe-clean the disc surface without scratching it. (Make sure to wipe from the centre of the disc towards the outer edge. Never use a circular motion.)

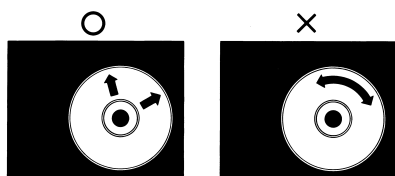

* Always from the centre to outer edge

(3) Do not use chemicals for disc cleaning.

- Never use any solvents other than those included in the cleaning kits.
- Never use analogue record cleaning fluid, benzene, alcohol or anti-static agent.

(4) Do not damage the label surface

- Damage to the label surface also affects the data surface immediately underneath it.
- Do not attach pieces of paper or adhesive tape to either side of the disc.
- When you need to write on the label surface, please use a permanent ink felt-tip pen. Writing implements with hard tips such as ball-point pens and pencils should not be used as they will damage the surface.

(5) Periodical cleaning of the discs is recommended.

- Periodical disc cleaning may be required depending on the equipment installation environment and disc handling method.

2. NAMES AND FUNCTIONS OF PARTS

2-1. Front panel, right side panel, rear panel

- ❶ **POWER switch** Turns the main unit power on/off. " | ":ON. " ○ ":OFF.
- ❷ **POWER Indicator** Lights up when the POWER switch is turned on. Blinks in case of error during operation.
- ❸ **LCD Display Panel** Shows information using alphanumeric characters.
- ❹ **MODE key** Used for LCD display page selection and other operations.
- ❺ **SELECT key** Used for switching displayed information and other operations.
- ❻ **LOAD/EJECT key** Opens or closes the mail slot.
- ❼ **ENTER key** Used for LCD page selection and other operations.
- ❽ **10-key** Used for selecting tray Nos. and changer SCSI ID Nos. for import/export operations.
- ❾ **Mail slot** Used for disc insertion/ejection
- ❿ **Key cylinder** After completing the door opening mode, insert a key and turn it counterclockwise to open the door.
- ⓫ **Rear panel** Opened and closed when installing or replacing drive units.
- ⓬ **SCSI connector** One SCSI connector port system is provided as standard.
- ⓭ **RS-232C connector** 9-pin D-sub connector (plug) for use in maintenance.
- ⓮ **AC inlet (main unit)** Insert the provided power cord and plug the other end of the power cord to a 120 V-240 V, 50 Hz/60 Hz AC power outlet.
- ⓯ **Side panel** To be removed in servicing.

■MC-8200LU (MC-8600LU)

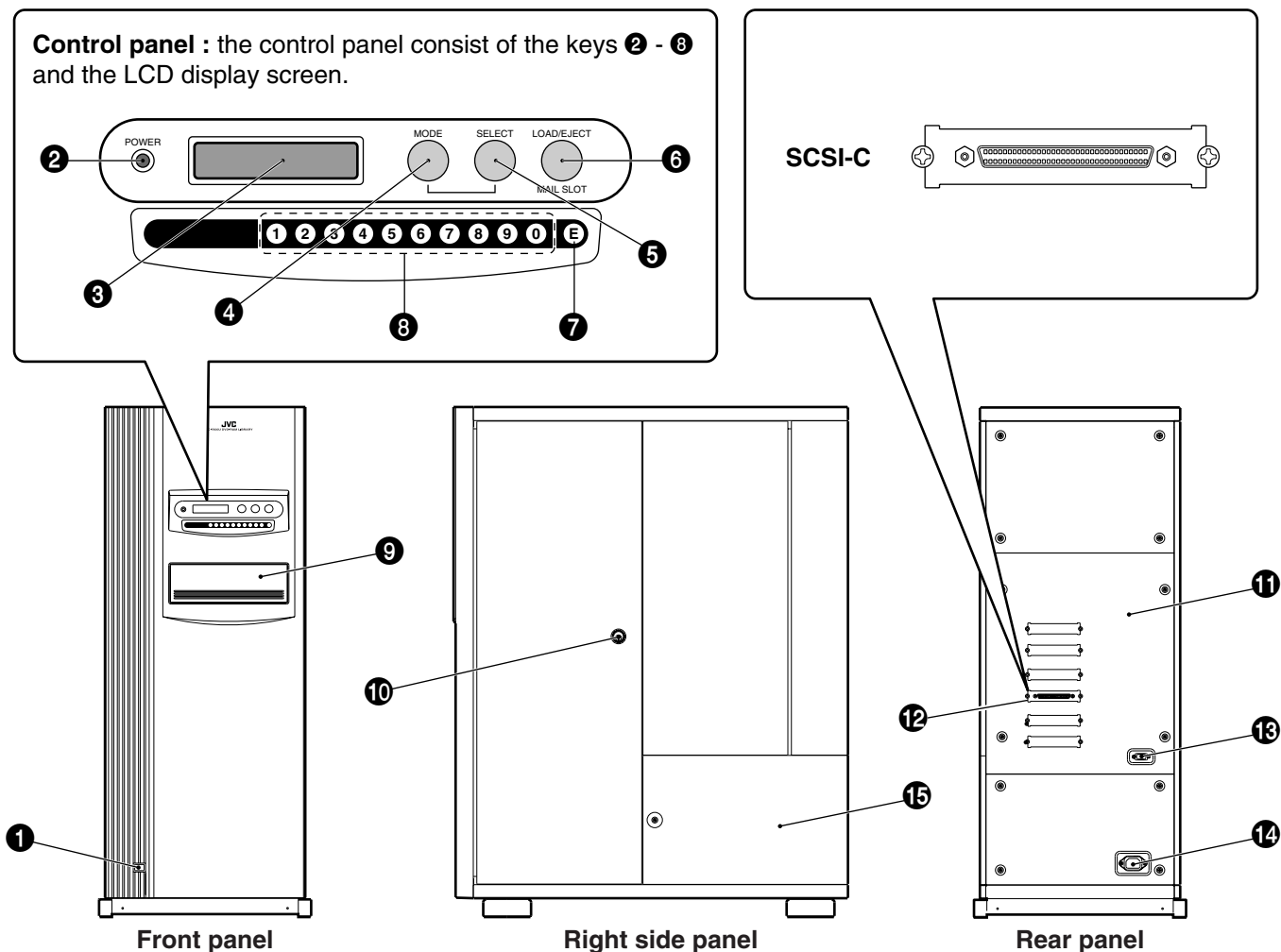

2-2. Interior

- ⑨ Mail slot Used for disc insertion/ejection.
- ⑰ Mail slot transport lock Locks the mail slot during transport.
- ⑱ Magazines Each magazine contains 50 trays accommodating up to 50 discs.
- ⑲ Drive bays Accommodation for up to 6 drive units is compatible with this product. The bays are numbered 1, 2, 3, 4, 5 and 6 from the bottom.
- ⑳ Carrier Transports the trays (discs) between the magazines and the mail slot, drives or printer.
- ㉑ Carrier transport lock Locks the carrier during transport.
- ㉒ Optional carrier transport lock To be locked before transport when the MC-CF10U Optional Carrier is installed.
- ㉓ Transport lock screw storage hole ... Attach the transport lock screw provided with the MC-CF10U Optional Carrier to this hole. (for optional carrier)
- ㉔ Center panel To be removed only for maintenance, etc. Do not normally remove this panel, as it provides hazard protection to the parts inside.

- The system for transporting the trays (discs) between the magazines and the mail slot or drives or printer using the carrier is generically referred to as the "changer".

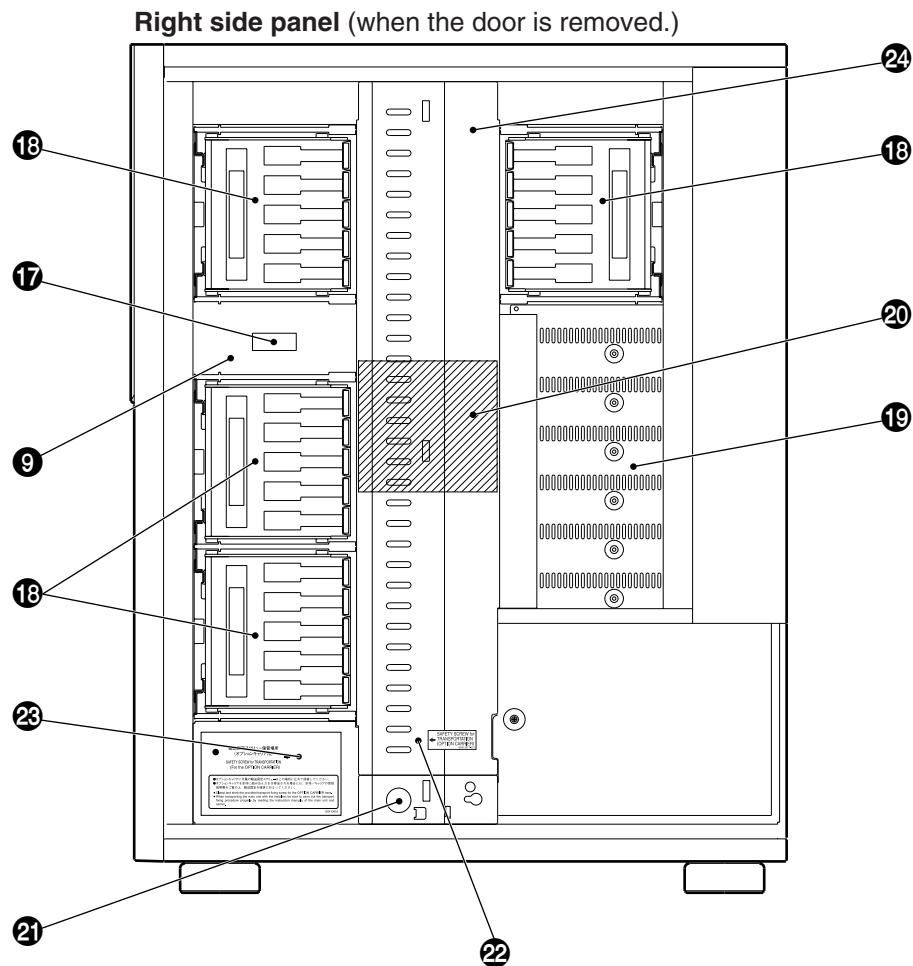

Names and Functions of Parts

2-3. Magazine numbers, tray numbers, disc numbers

The internal layout of the magazine and the numbers assigned to the magazines, trays and discs are as shown below.

- Magazine number** This is the number assigned to each of the 4 or 12 sets of magazines. The error message displayed when a magazine is inserted incompletely refers to the magazine number. (See page E27)
 Note, magazine number assignments are different from previous models (MC-1000, MC-2000 and MC-7000 Series).
- Tray number** This is the 2-digit number assigned to each of the 50 trays in each magazine. The combination of a tray number and magazine number corresponds to a disc number. For example, disc number 120 can also be represented as the disc in tray number 20 of magazine number 3. In this way, the disc can be located in the 20th slot from the bottom of magazine 3.
- Disc number** This is the 3-digit number assigned serially to every disc in all magazines and trays, starting from disc number 1 in tray 01 of magazine 1 up to disc number 200 or 600. The error messages usually refer to the disc numbers. (See page E30)

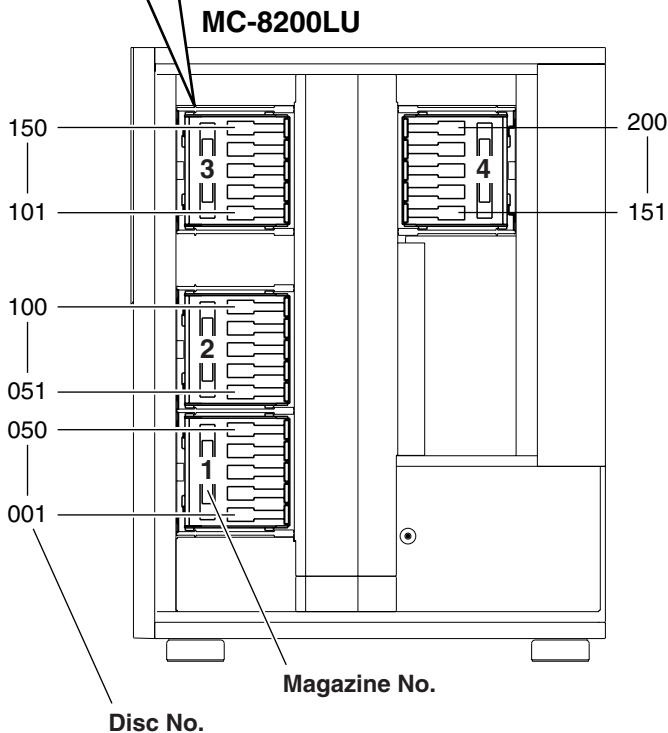
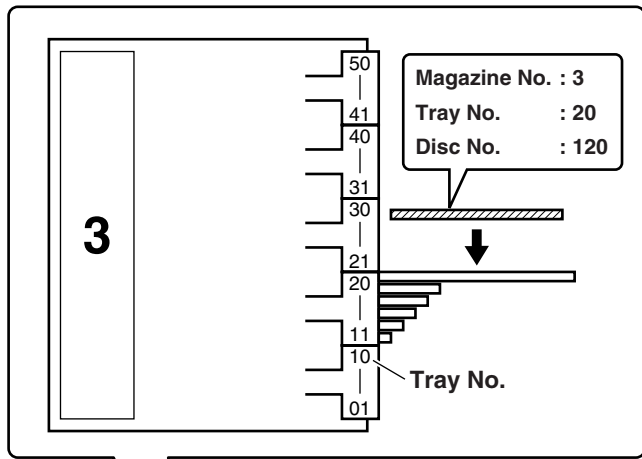

MC-8600LU

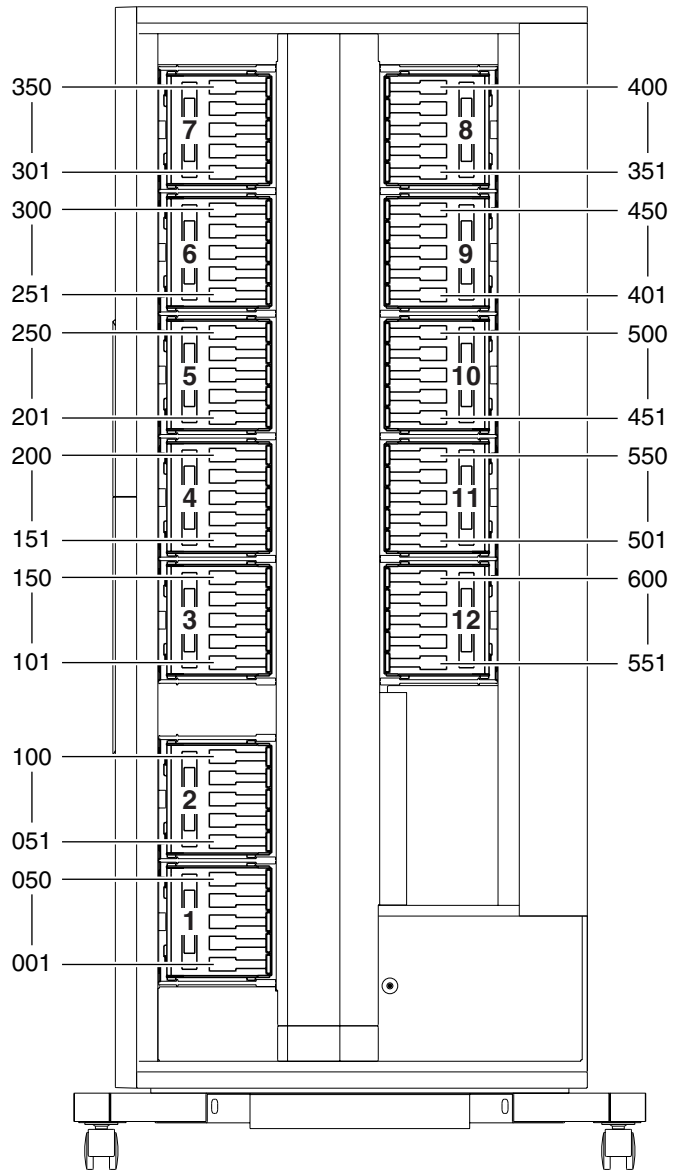

2-4. Internal SCSI cable

The SCSI connections inside the main unit (the Changer) are explained below:

The SCSI board, drive units and an SE (single-ended)/LVC (Low Voltage Differential) conversion board are daisy-chain connected by an internal SCSI cable. The length of the internal SCSI cable should be about 1.0 meter.

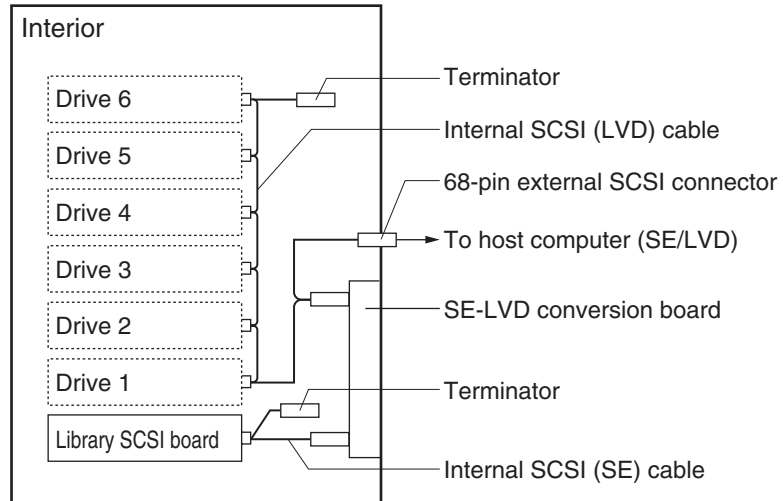

- Connectors that are not used should be capped in order to prevent short-circuiting.
- The physical extremity of the internal SCSI cable of the changer is terminated.

3. SETUP

The standard setup procedure is as shown below. Set up the equipment according to the procedure shown for each model.

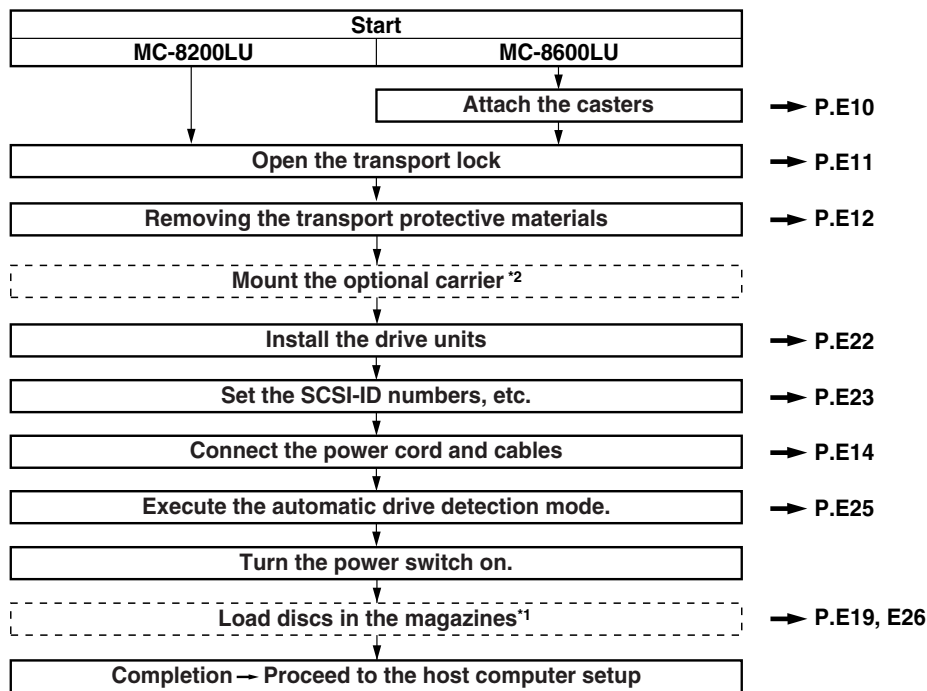

¹ A large number of discs can be loaded quickly(bulk load).

² Please have your dealer or nearest JVC service center perform this task.

3-1. Attaching the casters

The **MC-8600LU** comes standard with designated casters. Three or more persons should attach these casters by following the procedure below. Please also refer to the caster attaching procedure manual which is provided with the equipment.

1. After unpacking the equipment, take out the 4 casters from inside the bottom cushioning material.
2. Hold each caster with the wheel side down, and insert it into a caster socket on the bottom panel while sliding the lock pin as shown below.

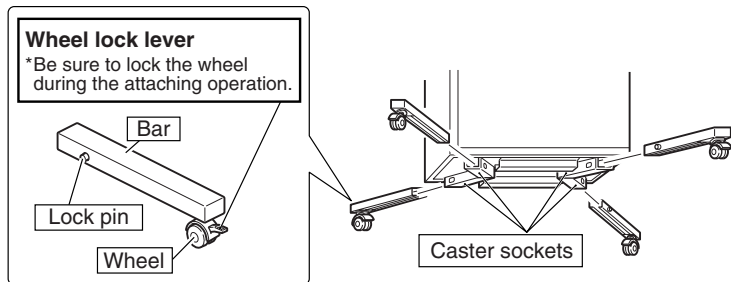

3. The caster is attached completely when the lock pin reaches and engages with the hole on the caster socket.
 - Make sure that the pin does not come out even when the caster is pulled strongly.

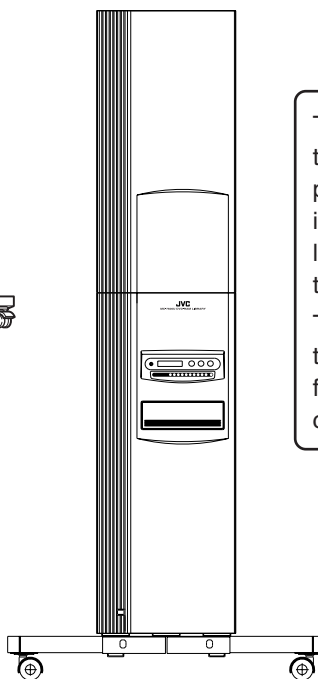
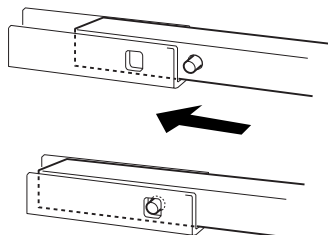

CAUTION:
The casters provided together with the **MC-8600LU** are exclusively for preventing the equipment from falling over and for changing its installation place and not for transportation.
Transporting the **MC-8600LU** on these casters on an uneven surface over a long distance may cause them to be damaged.

WARNING
Insert the casters until they are locked completely. Should an incompletely attached caster come out, the equipment may fall over and could cause an injury and damage to the equipment.

3-2. Opening the transport lock

1. Open the door by inserting the key and turning it counterclockwise (90°) to unlock the door.

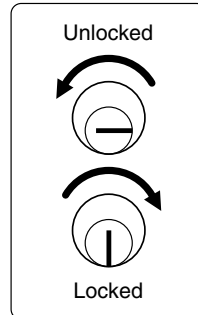

Door opening/closing key cylinder

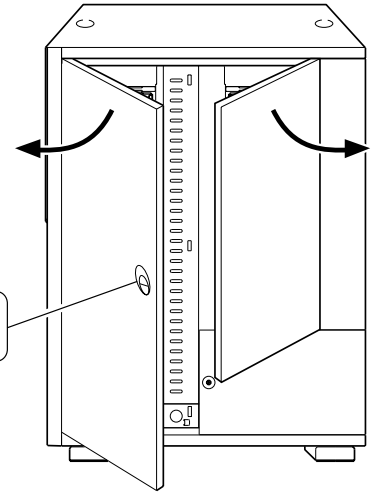

2. Open the transport lock of the mail slot.
 - Using a philips screwdriver, continue to turn the lock counterclockwise until the lock is completely disengaged and moves outwards.

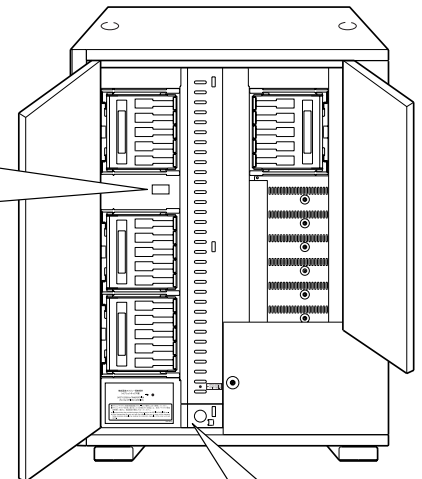
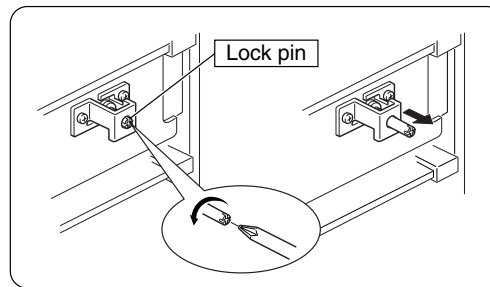

3. Open the transport lock of the carrier.
 - Continue to turn the screw counterclockwise to loosen it until the metal device retaining it is disengaged and moves outwards.

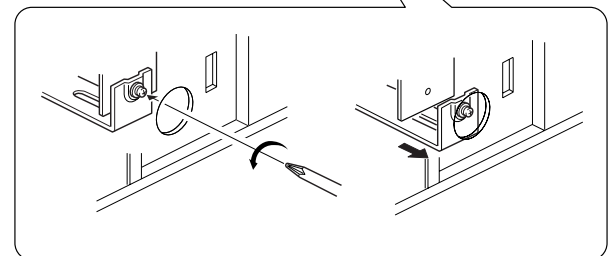

Note:

When using the **MC-CF10U** Optional Carrier, read "**3-4. Removing the optional carrier transport lock screw**" on page E13 before continuing on.

Proceed to the operation in the next page without closing the door.

- In the case of re-transporting, lock the transport lock as follows:
 - 1) Remove all the discs and turn off the power.
 - 2) Turn on the power while pressing the "1" of the 10-key pad and enter the PACKING mode.
 - 3) Turn off the power as soon as the "END" display appears on the LCD screen.
 - 4) Fix the transport lock as described in **2** and **3** above.
 - 5) When using the **MC-CF10U** Optional Carrier, read "**3-4. Removing the optional carrier transport lock screw**" on page E13 before continuing on.
 - 6) Re-attach the protective transport materials. (➡ See page E12.)

3-3. Removing the transport protective materials

After opening the transport lock, proceed to the following steps without closing the door.

1. Remove magazine No. 1.
(➔ See “9-1. Ejecting/loading the magazines” on page E27.)

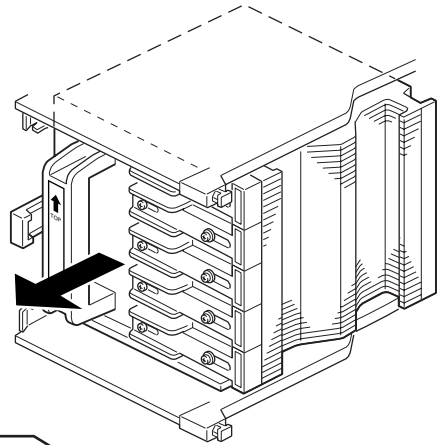

2. Pull out the protective material forwards.

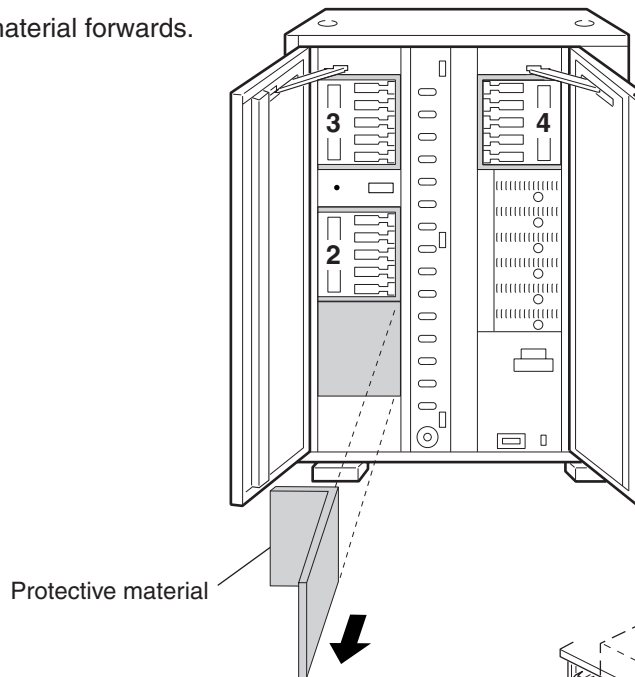

3. Load magazine No. 1.
(➔ See “9-1. Ejecting/loading the magazines” on page E27.)

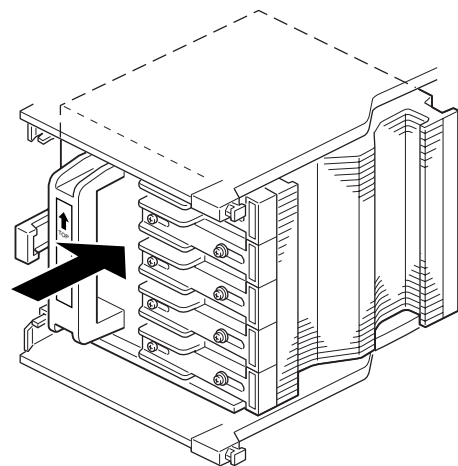

4. Repeat the same operation for each of the remaining magazines.

• In the case of re-transporting, it is necessary to remove all the discs and re-attach the protective transport materials using the reverse procedure to the above. When this operation is required, please consult your dealer or nearest JVC-authorized service agent.

3-4. Removing the optional carrier transport lock screw

When the **MC-CF10U** is installed, its special transport lock should be removed in addition to its being unlocked as detailed in "3-2. Opening the transport lock" on page E11. Use the following procedure when unlocking the optional carrier transport lock.

1. Remove the transport lock screw (for optional carrier).

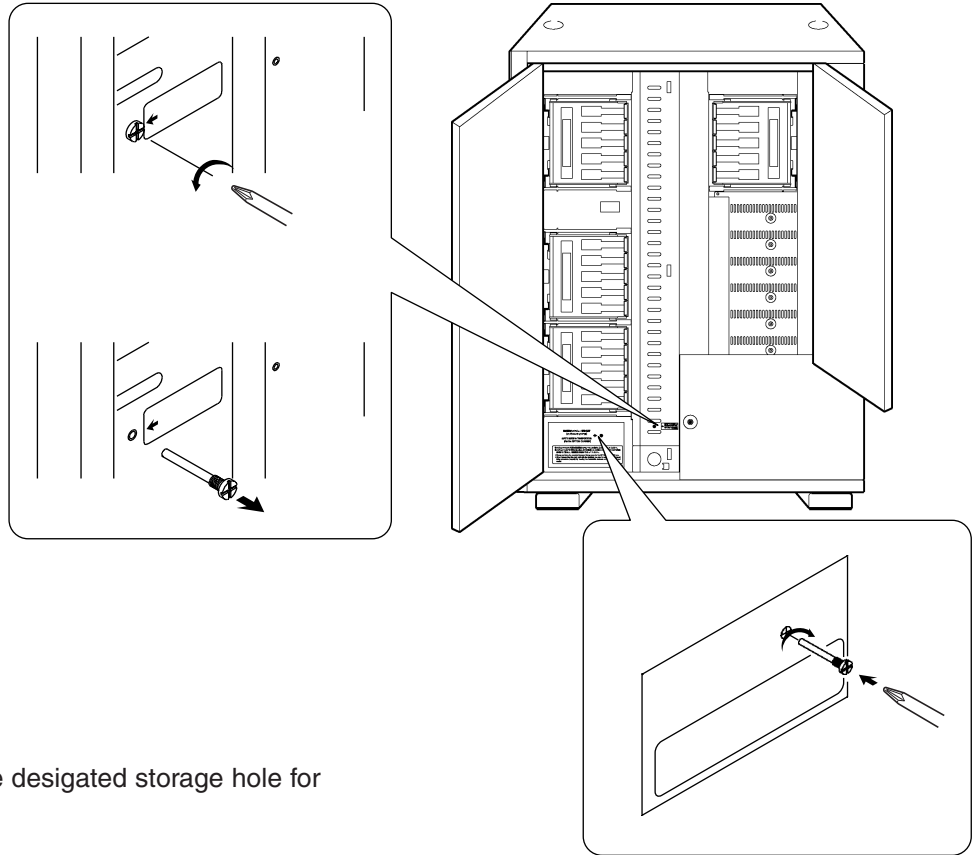

2. Insert the removed screw into the designated storage hole for the transport lock screw.

• If the system is transported with the **MC-CF10U** Optional Carrier installed, refer to "3-2. Opening the transport lock", execute the packing mode and clamp the above-mentioned transport lock screw.

3-5. Installing drives and settings SCSI-ID No., etc.

1. Installing drives

Install the drives (➔ See "7. DRIVE UNITS" on page E22).

2. Initial setting of SCSI-ID No., etc.

The default setting of the SCSI-ID No. of the MC-8200LU/8600LU is "0".

Set the SCSI-ID No. according to your system.

- To change the SCSI-ID No. of the MC-8200LU/8600LU ➔ Read "8. SETTING THE SCSI-ID NUMBERS OF THE MAIN UNIT" on page E26.
- To set the SCSI-ID Nos. and termination of drives ➔ Read the instruction manuals of the installed drives.

• As the MC-8200LU/8600LU should be turned on to allow its SCSI-ID No. to be set, read "3-6. Connecting the power cord and cables" on page E14 and connect the power cord before proceeding.

Setup

3-6. Connecting the power cord and cables

CAUTION

Turn OFF the power of all equipment before starting connections.
Connecting the equipment while power is ON may lead to a malfunction.

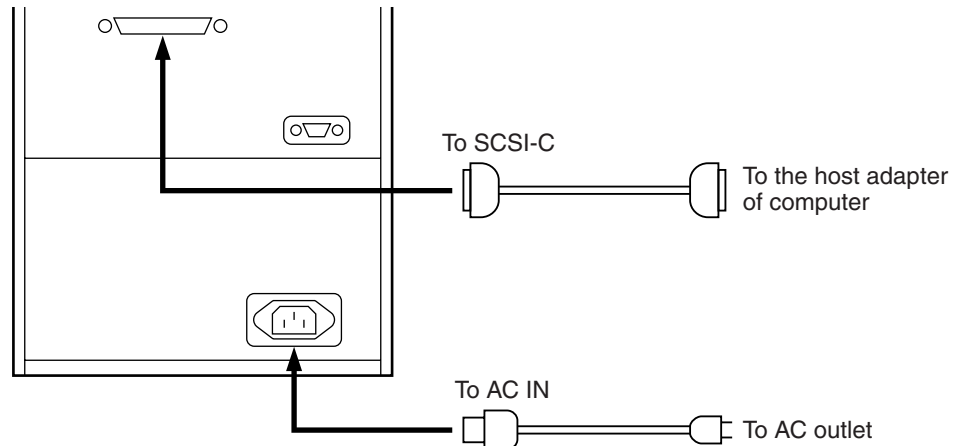

WARNING

Always use the power cord provided by JVC. The library system has been designed to conform to "Insulation category Class 1". In order to assure safety at all times, be sure to ground the system before use. If other types of power cords other than the specified cord are used, they may overheat and burn or cause a fire.

- The length of the internal SCSI cable is about 1.0 meter.
- Check the total length of the internal and external SCSI cables. A malfunction may occur if the lengths described below are exceeded.
 - 1) For use with an LVD: The maximum length of the external cable is 10 meters.
 - 2) For use with an SE (Narrow): The maximum length of the external cable is as follows.
 - SCSI-2, 20 Mbytes/s sync: 1.5 meter (Max. 2 drives)
 - SCSI-2, 10 Mbytes/s sync: 1.5 meter
 - SCSI-2, 5 Mbytes/s async: 4.5 meter
- Use an Ultra 160-compatible cable as the external cable. A malfunction may occur if any other cable is used.
- The host bus adapter in the controller computer should be LVD compatible.

- Recommended SCSI host adapters and SCSI cables
 - WINDOWS server
 - SCSI host adapter: ASC-29160 by ADAPTEC Co., Ltd.
 - SCSI cable: ACK-LVD-3M-U320 (3 m) by ADAPTEC Co., Ltd.
 - SUN work station
 - SCSI host adapter: PCI SCSI-2U3WL by Antares Microsystems Co., Ltd.
 - SCSI cable: ACK-68V-68HD-LVD (2 m) by ADAPTEC Co., Ltd.

Please consult your local JVC service center if a cable of a length other than the above mentioned or one that has been supplied by another manufacturer has been fitted.

Operation with a recommended host adapter is not guaranteed for a host computer in all cases. An adequate pre-operation examination is essential before starting an operation.

4. CONTROL PANEL OPERATIONS AND LCD DISPLAY

The switch operation and LCD display system has three operation and display modes as described below.

- **Normal display** This mode includes two patterns, one of which is displayed automatically when the equipment starts up normally. The disc numbers in the drive units are displayed in real time.
- **Menu display** This mode allows you to start user operations such as SCSI-ID No. checking and setting, internal history display and door/panel opening.
- **Event display** This mode overrides other modes in case of an event such as initialization after startup, mail slot operations, setting up the door/panel opening mode or appearance of errors.

4-1. Normal display

Pattern 1 is displayed automatically when the startup has succeeded normally. The display pattern will change every time the SELECT switch is pressed.

[Pattern 1]

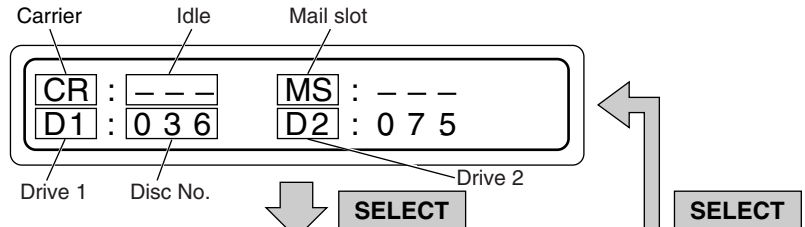

[Pattern 2]

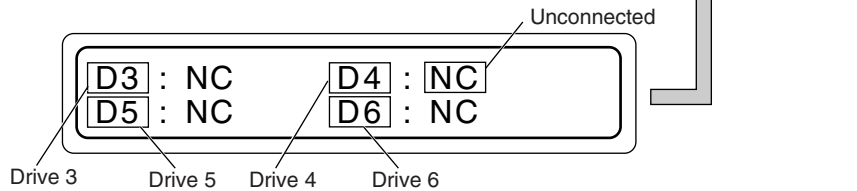

4-2. Menu display

Pressing the MODE key switch during normal display starts the menu display.

Select a menu by pressing the SELECT key and enter the selection by pressing the MODE key again.

- ① **NORMAL DISPLAY**
 (➔ See "4-1. Normal display" on this page.)
- ② **ERROR DISPLAY**
 (➔ See "10-4. Error history display" on page E32.)
- ③ **ID No. DISPLAY**
 (➔ See "8-1. Display for checking the SCSI ID numbers" on page E26.)
- ④ **PANEL OPEN**
- ⑤ **DOOR OPEN MODE**
 (➔ See "5. Door Opening/Closing" on page E18.)
- ⑥ **ID No. SET MODE**
 (➔ See "8. Setup of SCSI ID number of the main unit" on page E26.)
- ⑦ **COUNT DISPLAY**
 (➔ See "11. Access counts" on page E33.)
- ⑧ **IMPORT/EXPORT**
 (➔ See "6-2. Import/export operation" on page E20.)
- ⑨ **DRIVE DISPLAY**
 (➔ See "7-7. Drive type display" on page E25.)

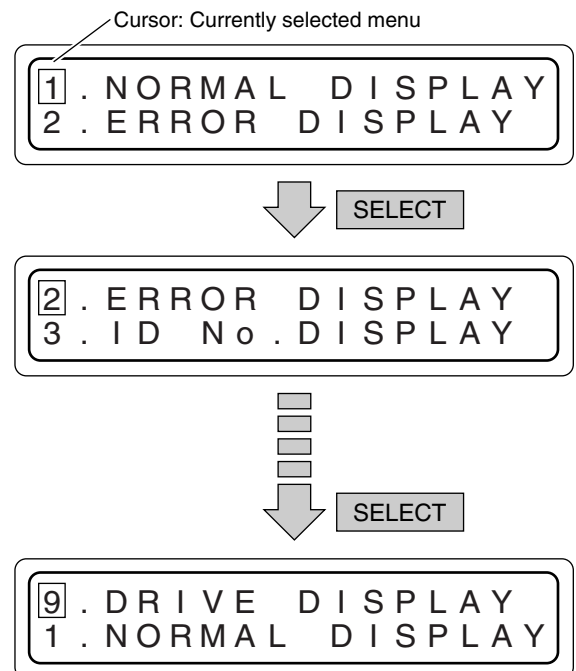

Control Panel Operations and LCD Display

4-3. Event display

① Power on

POWER ON

② During initialization

INITIALIZING

When the MC-CF10U Optional Carrier is installed

INITIALIZING
FLIP CARRIER

③ Error occurrence (⇒ See “10-2. Error code list” on page E31.)

ERROR OCCURRED!

Displayed
alternately.

DISC = 1 2 4
CODE = CU - 0 4

④ During door opening (⇒ See “5. Door Opening/Closing” on page E18.)

EXECUTING DOOR
OPEN PROCESS

→

THE DOOR
CAN BE OPENED

⑤ When door is open (⇒ See “5. Door Opening/Closing” on page E18.)

DOOR OR PANEL
IS OPEN

Door closing
→

PUSH ENTER KEY
TO RESUME

⑥ During mail slot operation (⇒ See “6. Mail Slot” on page E19.)

EXPORT DONE
PUSH LOAD KEY

4-4. Display and operation sequence

The sequence of display and operation after turning the power on is as shown below.

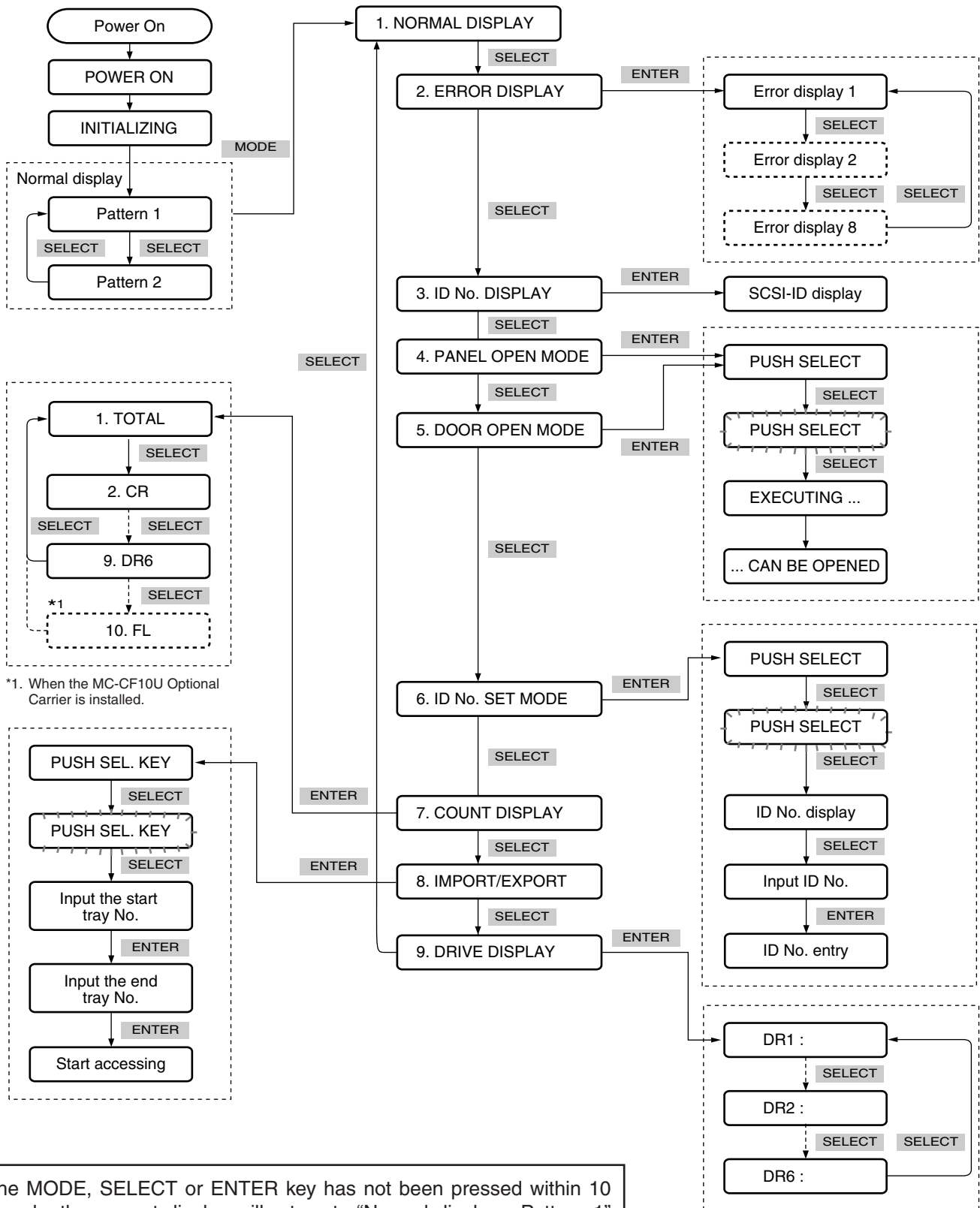

*1. When the MC-CF10U Optional Carrier is installed.

- If the MODE, SELECT or ENTER key has not been pressed within 10 seconds, the current display will return to “Normal display - Pattern 1” (except in a situation when an event is displayed or the Import/Export Tray numbers and SCSI-ID numbers are being input).

5. DOOR OPENING/CLOSING

Once the transport locks have been released and the power has been turned on for the first time, the door is locked by an internal safety lock in addition to the key so that the door cannot be opened with the key alone.

In order to open the door with the key under these conditions, either maintain or turn on the power supply if it has not been turned on yet, and perform the following operations before inserting and turning the key.

■Door Opening

1. In the normal display mode, press the MODE Key.
(The menu display appears.)

1 . NORMAL DISPLAY
2 . ERROR DISPLAY

2. Press the SELECT key 4 times.
("5. DOOR OPEN MODE" appears.)

5 . DOOR OPEN MODE
6 . ID No . SET MODE

3. Press the ENTER key.
(Select and enter "5. DOOR OPEN MODE".)

PUSH SELECT KEY
TO OPEN THE DOOR

4. Press and hold the SELECT key for more than 5 seconds.
(Wait until the display starts to blink.)

PUSH SELECT KEY
TO OPEN THE DOOR

5. Release the SELECT key when the execution display [EXECUTING DOOR OPEN PROCESS] appears.
* When inserting/ejecting a drive unit, turn off the power after the completion display [THE DOOR CAN BE OPENED] appears.

EXECUTING DOOR
OPEN PROCESS

6. Insert the door opening/closing key in the cylinder and turn it counterclockwise to release the lock and open the door.

THE DOOR
CAN BE OPENED

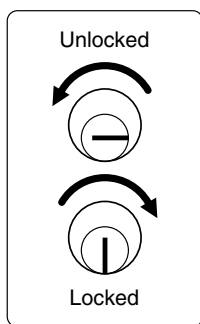

The door opening/closing key cylinder (lock)

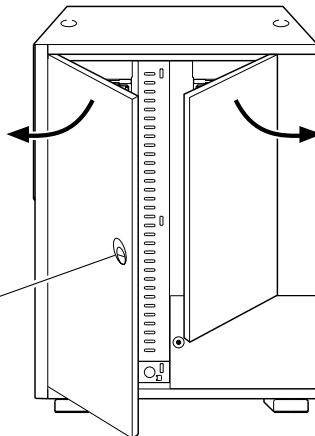

The door is open.

DOOR OR PANEL
IS OPEN

The door is closed.

PUSH ENTER KEY
TO RESUME

■Door Closing

1. Close the door and turn the door opening/closing key clockwise to lock.

2. Press the ENTER key switch when the display shown on the right appears.
* The screen will return to the Normal display after initialization.

• You cannot perform disc transport operations when the above the door open mode is being executed or the door is open.

6. MAIL SLOT

6-1. Disc loading

CAUTION
Do not load or eject a disc before the mail slot has stopped completely. It may not only damage the disc but also cause the equipment to malfunction because of excessive force being applied during opening and closing.

Disc loading/ejection method
When a tray is transported to the mail slot under the control of the host computer or the import/export operation (➔ P. E20), the mail slot opens automatically when transportation has been completed.

1. Place a disc gently on the tray with a label surface facing upwards.
(To remove a disc from the tray, hold the disc by the center hole and the outer edge which is accessible near the notched section on the front side of the tray.)

EXPORT DONE
PUSH LOAD KEY

CAUTION
• A DVD-RAM disc may become impossible to write/read due to dust, fingerprints, scratches, etc. adhering to the disc surface. Please handle it carefully. Take special care in handling the DVD-RAM/R discs because they are extremely vulnerable to scratches and contamination.

CAUTION
Media compatible with the MC-8200LU/8600LU varies depending on the installed drive types. For details, refer to the instruction manuals of the drives.

CAUTION
When using double-sided discs, handle them with special care because they do not have a label on the surface.

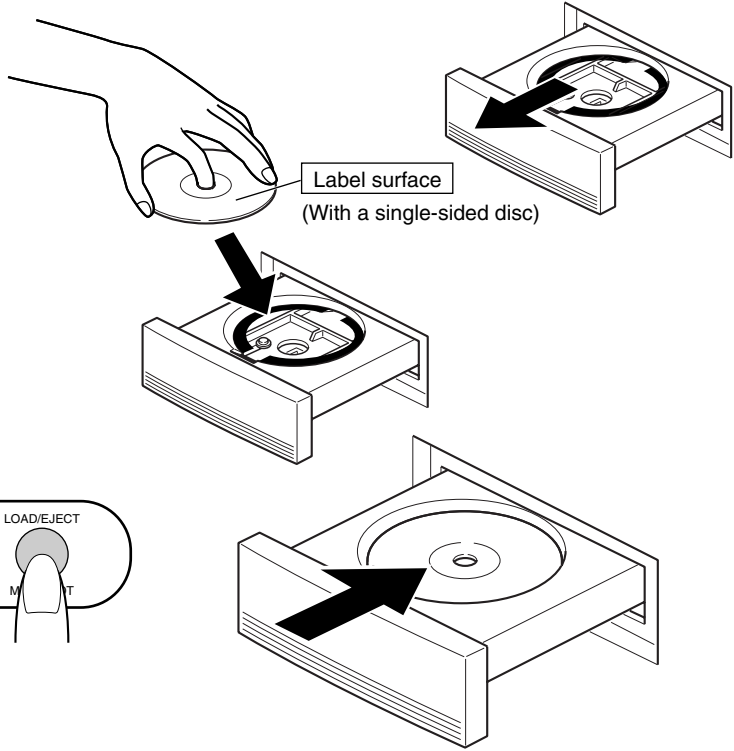

2. Press the LOAD/EJECT key.
(The mail slot closes.)

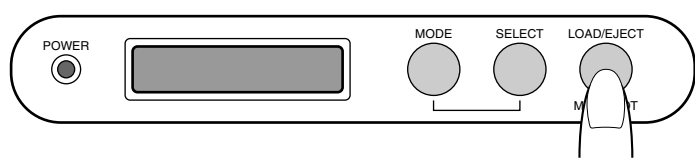

- Now you can repeat the open/close operations alternately by pressing the LOAD/EJECT key provided that the mail slot transportation operation has not started yet.
- While the carrier is in operation, pressing the LOAD/EJECT key will not start the open/close operations.

CAUTION
• Never use a damaged and/or warped disc or a disc with an attached label. It will lead to a malfunction of the equipment.
• If you are going to use a disc from a different drive, please check the drive specifications carefully before using it. (Some drives may not be able to read the disc.)
(At the same time, the equipment may not be able to read the disc which has been written and deleted in a different drive.)
• Note that some double-sided discs do not provide a distinction between the top and bottom sides. Take special care when removing/loading these discs from/in the MC-8200LU/8600LU.

6-2. Import/export operation

When loading/ejecting discs from any chosen tray by the mail slot without the control of the host computer, follow the procedure shown below.

- During the import/export operation, the host computer commands which include the carrier operations cannot be executed.

1. In the normal display mode, press the MODE key.
(The menu display appears.)

```
1 . NORMAL DISPLAY
2 . ERROR DISPLAY
```

2. Press the SELECT key 7 times.
("8. IMPORT/EXPORT" appears.)

```
8 . IMPORT / EXPORT
9 . DRIVE DISPLAY
```

3. Press the ENTER key.
(Select "8. IMPORT/EXPORT".)

```
PUSH SEL . KEY FOR
IMPORT / EXPORT
```

4. Press and hold the SELECT key for more than 5 seconds.
(Wait until the display starts to blink.)

```
PUSH SEL . KEY FOR
IMPORT / EXPORT
```

5. Release the SELECT key when the input start tray message is prompted.

```
INPUT START
TRAY No . : ---
```

6. Enter the start tray number(001-200*¹) using the 10-key pad.
•If the number is wrong, input a new 3-digit tray No.(ex. 001) again.

```
INPUT START | | |
TRAY No . ÷ 1 1 5 -
```

7. Press the ENTER key.

8. Enter the end tray number(001-200*¹) using the 10-key pad.
•If you wish to use the import/export operation for a single disc, either enter the same end tray number as the start tray number or press the ENTER key without entering any number.

```
INPUT END
TRAY No . : ---
```

9. Press the ENTER key.

```
INPUT END | | |
TRAY No . ÷ 1 2 4 -
```

- You can cancel the following operations by pressing and holding the ENTER key for 5 seconds during the import/export operation. If the mail slot opens after cancelling the operation, press the LOAD/EJECT key.(The tray in operation will be returned to the magazine; then the import/export operation will be completed.)

```
IMPORT / EXPORT
TRAY No . : 1 1 5
```

*¹ MC-8200LU. (001 - 600 for the MC-8600LU)

- 10.** When the mail slot automatically opens, place the desired disc on the tray (number is displayed on the LCD).
 (➔ See "6-1. Disc loading" on page E19.)
- To remove a disc, lift it out of the tray.
 - When the following message appears on the LCD display, it is possible that the transport lock of the mail slot has not been properly released. Please make sure that that lock pin has been removed completely. (➔ See "3-2. Opening the transport lock" on page E11.)

CHECK THE LOCK
PIN!

Press the MODE key to return to the menu display.

- 11.** Press the LOAD/EJECT key. (The mail slot closes and the tray is returned to the magazine.)

- 12.** When continuous import/export operations are required, repeat steps **10** and **11**.

(The tray number on the LCD display will increment by one.)

- If the tray cannot be found in the magazine (including instances when the tray is in a drive or the color disc printer), this tray No. will automatically show up on the LCD display and then the import/export operation will be completed.

NO TRAY
TRAY No. : 115

Press the MODE key to return to the menu display.

In the following instances, the import/export operation cannot be performed and the LCD display will indicate as shown on the right.

Clear the following conditions on the host computer side first and then input again.

- When a tray is in the mail slot.
- When the carrier operation is being executed.
- When the host computer control is prohibiting import/export operations.

IMPORT / EXPORT
IS PROHIBITED

- If the disc location in the main unit (the changer) has been altered or the contents of a disc have changed because of import/export operations, the disc location data on the host computer should, as a rule, be renewed. (Hardware and software must stay in sync for proper operation).

7. DRIVE UNITS

CAUTION

- Make sure that the power is turned off when installing/removing, connecting or setting a drives. Performing these operations while the power is on will result in the equipment malfunctioning. Be sure to read the instruction manuals of the drive units before proceeding to any of the following work.
- Note that certain device drivers are incompatible with the simultaneous use of more than one type of drive (mixed use). Please consult your dealer or nearest JVC service center.

7-1. Removing the panel

1. Open the door.
(➔ See "5. Door Opening/Closing" on page E18.)
2. Turn off the power.
3. Remove the drive bay panel.
 - Remove the 4 screws.
 - Carefully disconnect the SCSI cable from the drive.
(➔ See "7-4 Connecting the cables" on page E23.)
 - Unplug both the internal SCSI (SE) cable (50P cable) and the LVD power cable (6P cable) from the connectors on the SE-LVD conversion board.

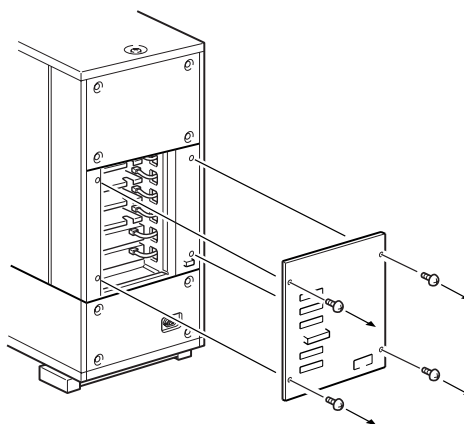

7-2. Installing the drive units

- When removing the drive units, be sure to disconnect the control cable and power cable beforehand.
(➔ See "7-4. Connecting the cables" on page E23.)

1. Inserting a drive unit.
 - Always insert it into a bay with the lowest available bay No.(from bottom to top)
 - Be careful not to snag any cables.
 - Be careful not to damage the sensor slit.

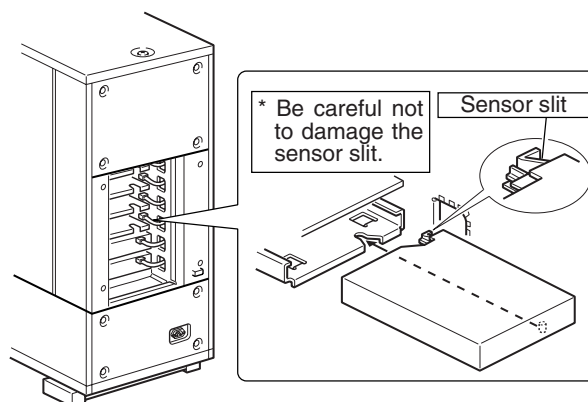

2. Secure the drive using the provided metric screws.
 - The provided metric screws are attached to the optional drive unit.

CAUTION

Be sure to attach the screws securely. If the library system is operated without the screws, either the library or the drives may be damaged.

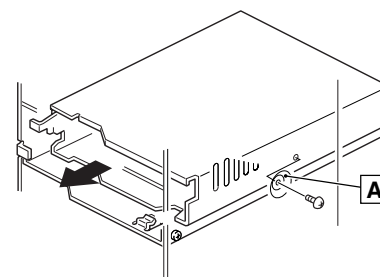
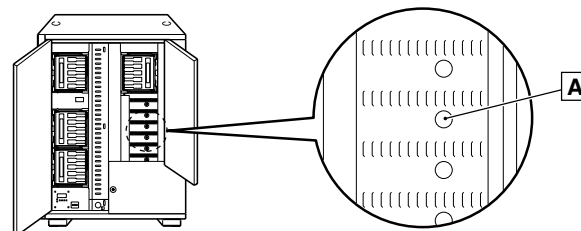

7-3. Setting the SCSI-ID Numbers, etc.

- Procedure for setting the SCSI-ID No. and other jumper settings.
Please refer to the specified section(s) of the corresponding drive instruction manual.
- Make sure to turn the power OFF before starting the procedure. If the procedure is carried out with the power ON, it will cause malfunction.
- The new ID Nos. will become effective from the the moment the power is turned on.
- The new SCSI ID Nos. should not conflict with the ID Nos. of other SCSI equipment on the same SCSI bus.
- The SCSI ID numbers should be in the range from 0 to 7. Numbers from 8 to 15 cannot be used.

7-4. Connecting the cables

- For the positions of the connectors for the cables from the optional drives, please refer to the relevant instruction manuals for the drives.

1. Connect the control cable (14P).
 - Connect the control cable having the same number as the drive bay number.
2. Connect the power cable (14P).
(The figure shows the case of the MC-R434U.)
3. Connect the two LVD power cables (6P) to the SE-LVD conversion board.
 - Both cables have identical connector types, so that either cable can be connected to either connector on the SE-LVD conversion board.
4. Connect the internal SCSI (SE) cable (50P) to the SE-LVD conversion board.
 - The other end of the internal SCSI (SE) cable is connected to the library SCSI board in the library.
5. Connect the internal SCSI (LVD) cable (68P) to the drives.
 - The other end of the internal SCSI (LVD) cable is connected to the SE-LVD conversion board.

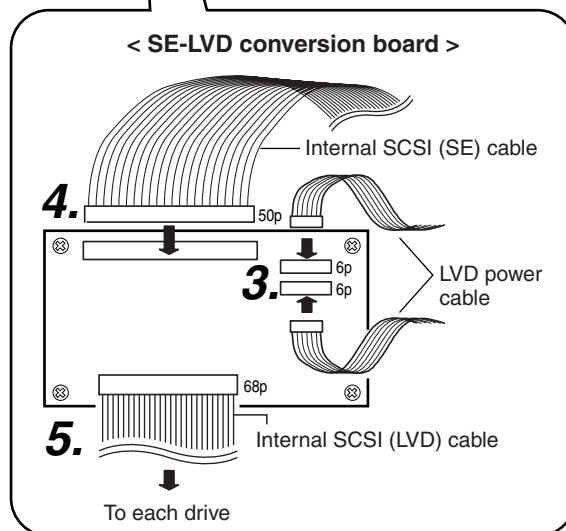
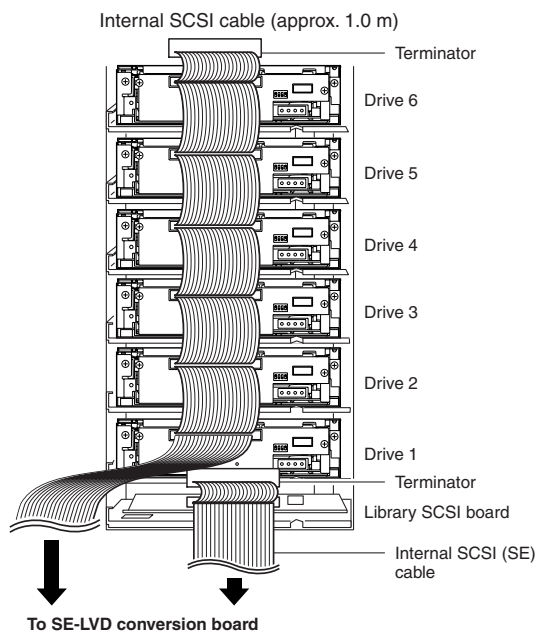
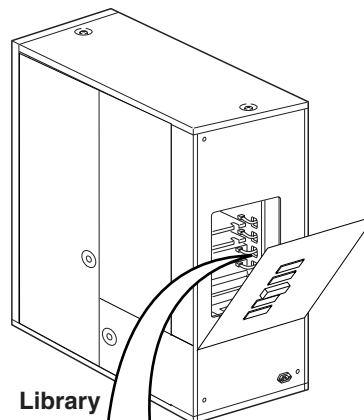
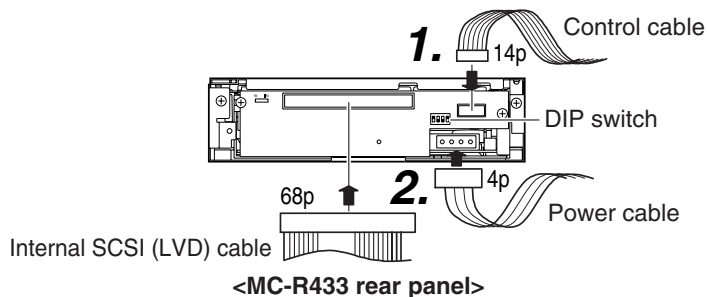

Drive Units

7-5. Installing the panels

CAUTION

- Check the installation screws and cables before installing the panel. Insufficient connections may cause malfunctions.

1. Attach rear and side panels.
 - Screw the panels on, following the procedure in "7-1 Removing the panel" on page E22 in the reverse order.
2. Close the door
(➔ See "5. Door Opening/Closing" on page E18.)

7-6. Automatic drive detection mode

Note:

After installing, adding, exchanging or removing drives, be sure to execute the auto drive detection mode to prevent any malfunction.

1. While holding the "8" key on the control panel, turn on the MC-8200LU/8600LU.
2. When the LCD display shows "DRIVE DETECTION COMPLETED", turn off the power of the MC-8200LU/8600LU.
3. Turn the MC-8200LU/8600LU on again.

DETECTING DRIVES
..... PLEASE WAIT

DRIVE DETECTION
COMPLEED

7-7. Drive type display

Check the types of the installed drives as follows.

1. Press the MODE key while the LCD display is in normal display mode (to display Menu display).
2. Press the SELECT key 8 times (to display "9. DRIVE DISPLAY").
3. Press the ENTER key (to select "9. DRIVE DISPLAY").
4. The type of the drive in each drive bay will be displayed. (Each press of the SELECT key displays the information on the next drive.)

1 . NORMAL DISPLAY
2 . ERROR DISPLAY

9 . DRIVE DISPLAY
1 . NORMAL DISPLAY

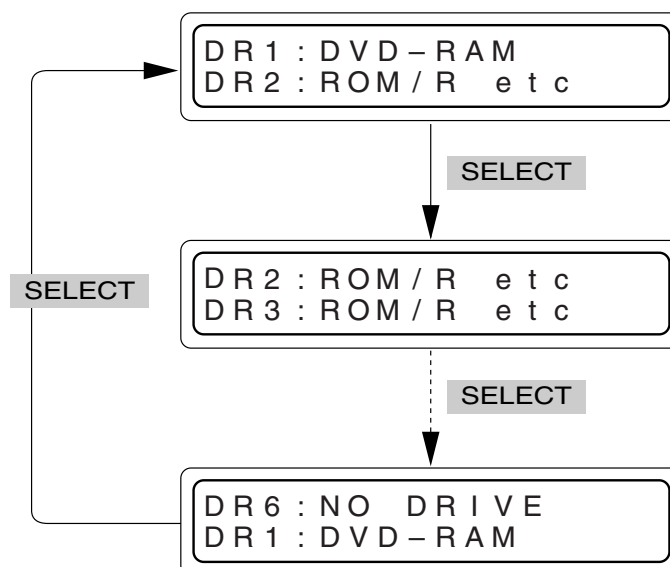

UNKNOWN DRIVE
TYPE DETECTED

Meaning of the display

"DVD-RAM" : DVD-RAM/R drive

"NO DRIVE" : Drive is not connected or installed

"ROM/R etc" : Non DVD-RAM/R drive (CD-ROM/R, DVD-ROM, etc.)

"UNKNOWN" : When drive detection mode has not been executed.

- If the automatic drive detection mode has not been executed, the LCD displays "UNKNOWN DRIVE DETECTED".
- If the type displayed for an installed drive is erroneous or if [NO DRIVE] or [UNKNOWN] is displayed, the cable connection to the drive may be missing or the wrong one. Check the cable connection and drive type again.

8. SETTING THE SCSI-ID NUMBERS OF THE MAIN UNIT

Perform the following operations when changing the setting of the SCSI-ID Nos. of the main unit (changer).

1. In the normal display mode, press the MODE switch.
(the menu display returns.)

```

1 . NORMAL DISPLAY
2 . ERROR DISPLAY
    
```

2. Press the SELECT key 5 times.
("6. ID No. SET MODE" appears.)

```

6 . ID No . SET MODE
7 . COUNT DISPLAY
    
```

3. Press the ENTER key.
(Select and enter "6. ID No. SET MODE".)

```

PUSH SELECT KEY
TO CHANGE ID No .
    
```

4. Press and hold the SELECT key for more than 5 seconds.
(Wait until the display starts to blink.)

```

PUSH SELECT KEY
TO CHANGE ID No .
    
```

5. Release the SELECT key when the current ID No. is displayed.

```

CHANGER
SCSI ID No . = 0
    
```

6. Select a new ID No. using the keys 0 to 7.

```

CHANGER
SCSI ID No . = 3
    
```

7. Press the ENTER key. (The ID No. being displayed is entered.)
 - The set ID No. becomes effective from the next time power is turned on.

```

CHANGER ID No .
IS SET TO 3
    
```

- The new SCSI ID Nos. should not conflict with the ID Nos. of other SCSI equipment on the same SCSI bus.
- The SCSI ID numbers should be in the range from 0 to 7. Numbers from 8 to 15 cannot be used.
- If the server connected to the changer runs Windows 2000 as the OS, the operations may be unstable. To ensure stable operation, change the SCSI ID No. of the changer to an unused number, for example 6.

8-1. Display for checking the SCSI ID numbers

Perform the following operations when display of the current SCSI-ID Nos. of the main unit and the drive units is required.

1. In the normal display mode, press the MODE key.
(the menu display appears.)

```

1 . NORMAL DISPLAY
2 . ERROR DISPLAY
    
```

2. Press the SELECT key twice.
("3. ID No. DISPLAY" appears.)

```

3 . ID No . DISPLAY
4 . PANEL OPEN
    
```

3. Press the MODE key.
(Select and enter "3. ID No. DISPLAY".)
The following will be displayed.
CH: Changer
DR1 - 6: Drive 1-6 ("- indicates "Not Connected")

```

CH DR1 2 3 4 5 6
0 1 2 - - - -
    
```

9. MAGAZINES

CAUTION

- Do not use a magazine which has been damaged (e.g. dropped), as normal operation cannot be accomplished with such a magazine. In addition, the use of such a magazine may damage the internal mechanism.
- The magazines and trays used with the MC-1000/2000 series CD-ROM Library and MC-7000 series DVD-RAM Library are not compatible with those used with the MC-8000 series CD/DVD Library. Do not interchange the magazines and trays between these models, as this will damage the equipment.
- If it is required to take out or attach a magazine during operation, be sure to perform optimum software processing at the host in advance.

9-1. Ejecting/loading the magazines

Ejection

1. Open the door. (➡ See "5. Door Opening/Closing" on page E18.)
* Do not turn off the power switch.
2. Pull the release lever toward the front.
 - The magazine unlocks and comes out slightly toward the front. Be careful not to get your finger caught between the release lever and grip.
3. Pull the magazine straight toward the front.
 - Use care not to hit or drop the magazine.
 - Be careful not to touch the tray lock by mistake. A tray may spring out.

Loading

1. Check the orientation of the magazine.
 - The [↑ TOP] marking is provided on the grip to indicate the upper direction of the magazine.
2. Align the magazine rails with the guide on the main unit (changer) and insert it straight forward.
 - Insert the magazine slowly. Inserting it with a strong force may damage the equipment.
 - Ensure that the magazine guides are fitted in the guides located at the left or right sides of the library (both at the top and bottom of the sides).
3. Push in the magazine completely until it stops.
 - Then, pull the magazine slightly toward the front to ensure that it is locked.
4. Close the door (See "5. Door Opening/Closing" on page E18.)

* If a magazine was removed and installed and then the door closed after the power has been turned on, this function will automatically check the disc status inside the magazine. (provided that the automatic disc checking function has been turned ON ➡ P.E29).

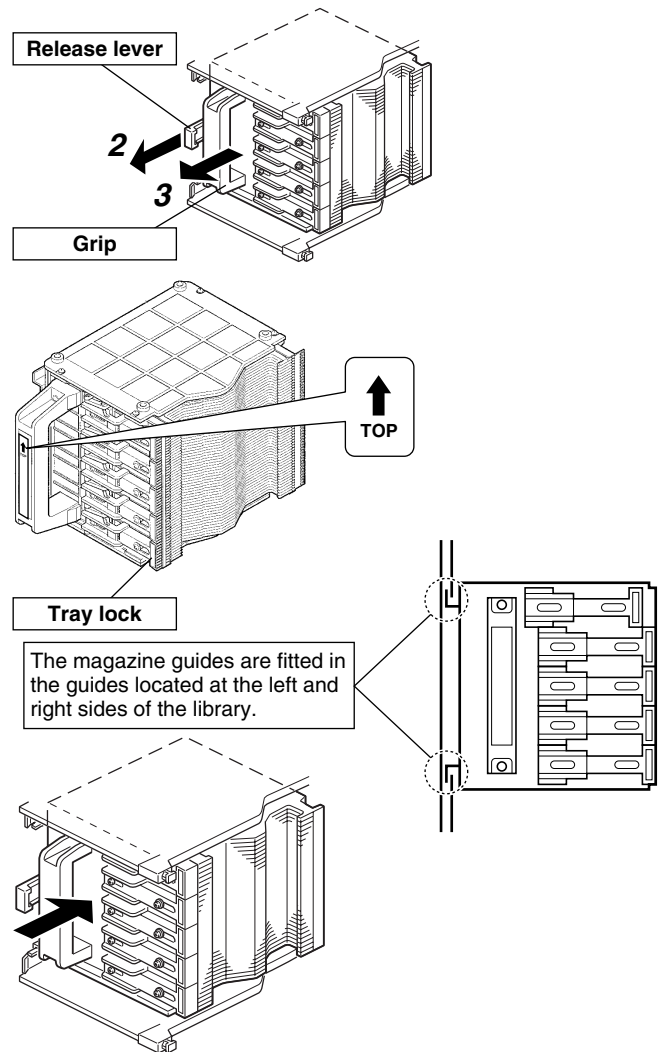

Display in case of incomplete insertion

The front panel display will indicate an error if the door is closed while the magazine insertion is incomplete. Check the incorrectly inserted magazines from the displayed message and re-insert them completely until they are locked.

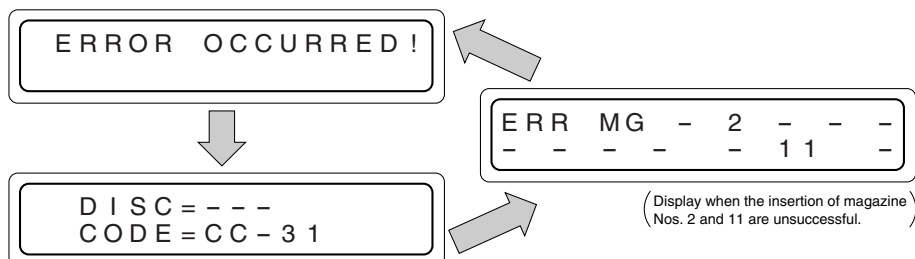

Magazines

9-2. Loading/replacing the discs

CAUTION

- When loading discs directly into the magazine trays without using the mail slot, be careful not to damage the magazines and trays.
- A disc may become impossible to write/read due to dust, fingerprints, scratches, etc. adhering to the disc surface. Please handle it carefully.
- Take special care in handling the DVD-RAM discs because they are extremely vulnerable to scratches and contamination.
- Media compatible with the MC-8200LU/8600LU varies depending on the drive configuration. For details, refer to the instruction manuals of the drives.

When using double-sided discs, handle them with special care because they do not have a label on the surface.

- Never use a damaged and/or warped disc or a disc with an attached label. It will lead to a malfunction of the equipment.
- If you are going to use a disc which has been used with this equipment from a different drive, please check the drive specifications carefully before using it.

(Some drives may not be able to read the disc.)

(At the same time, the equipment may not be able to read the disc which has been written and deleted in a different drive.)

- Note that some double-sided discs do not provide a distinction between the top and bottom sides. Take special care when removing/loading these discs from/in the MC-8200LU/8600LU.

1. Eject a magazine. (➔ See “9-1. Ejecting/loading the magazines” on page E27.)
2. Unlock the tray lock corresponding to the tray to be used. (➔ See “2-3. Magazine numbers, tray numbers, disc numbers” on page 8.)

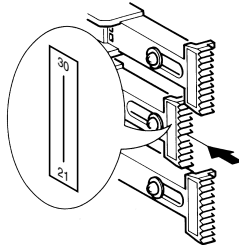

3. Pull out the tray.

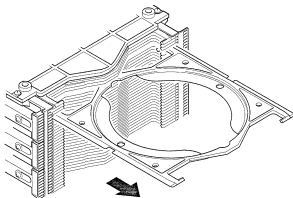

4. Place the disc on the tray.

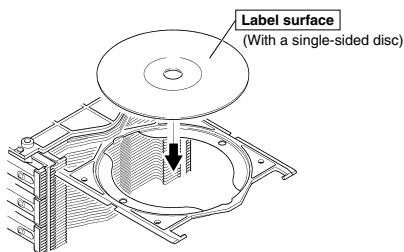

5. Push in the tray and lock the tray lock.
6. Load the magazine in the changer. (➔ See “9-1. Ejecting/loading the magazines” on page E27.)

CAUTION

- (1) Place the disc correctly on the disc tray so that it does stay in the guide section of the disc tray.

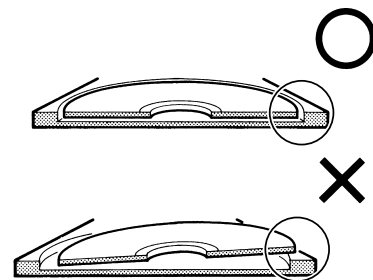

- (2) To prevent projection of a tray or incomplete locking of the tray lock, align the edges of all the trays in the magazine by slightly pushing them inward from the top to the bottom with your finger.

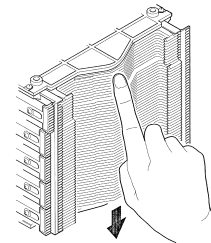

- (3) Always handle the magazine the correct way. Holding or placing a magazine upside down or on its side may cause the discs to slip out of position and result in malfunction.

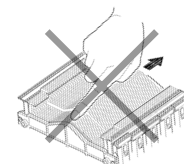

9-3. Automatic disc checking function

If a magazine was removed and reinstalled after the power had been turned on, this function will automatically check the disc status inside the magazine.

■ Checking the operation modes.

Press and hold the MODE switch for more than 5 seconds.

- The factory default setting for the automatic disc checking function is on.

Automatic disc checking function ON



Automatic disc checking function OFF



■ Switching the operation modes

Operation modes will alternate (toggle) when you turn the power off, and then on while pressing both the SELECT and the LOAD/EJECT keys simultaneously.

- Depending on the management software used, you may still have to update the disc status data of the host computer even after the automatic disc checking function has updated the disc status data of a magazine.

10. ERROR CODES

In the event an error, the control panel indicator blinks and the LCD shows the error details by overriding any other information.

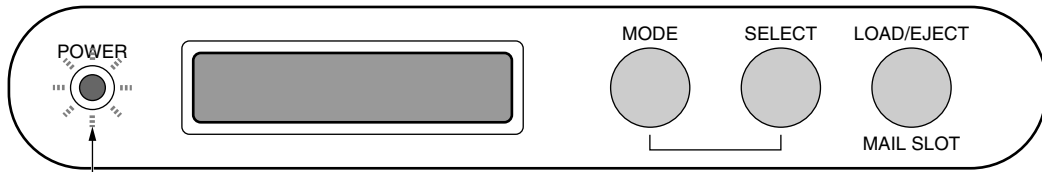

The indicator blinks.

10-1. Error code explanation

LCD displays in the event of error

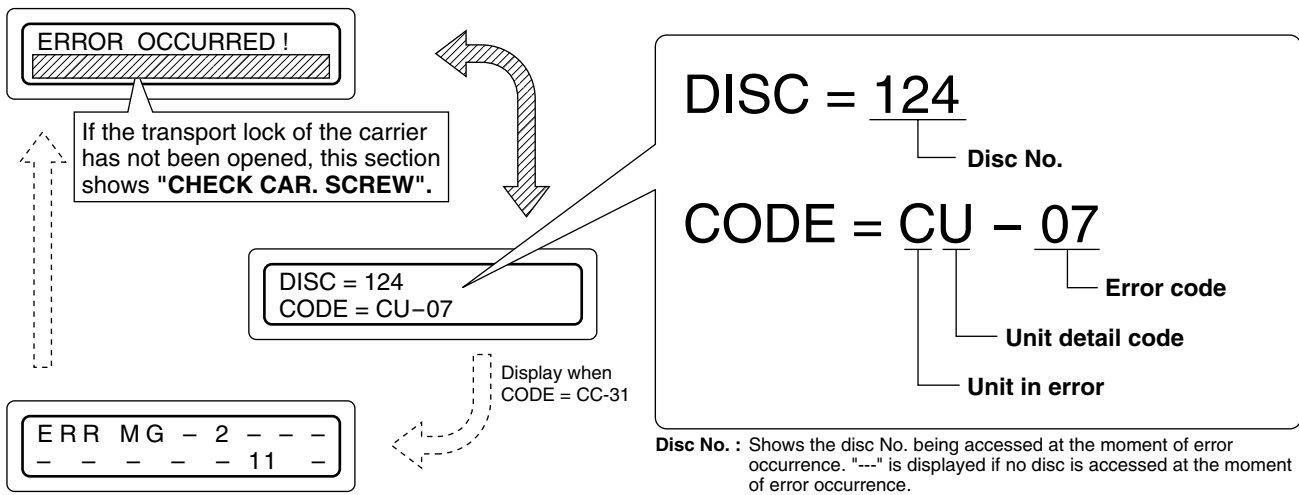

Units in error and unit detail codes

Unit in error		Unit detail code	
C	Carrier	U	Up/down
		L	Tray lock
		C	Catcher
		D	Disc
		F	Flip
M	Mail slot	E	Ejection
		L	Loading
		T	Tray
D1 to D4	Drive	T	Tray
		C	Clamp
		E	Ejection
		D	Disc
		S	Spindle

- When an error occurs, write down the error code before turning the power off, except in the case of an urgent problem such as smoke.
- When an error occurs, make sure not to turn off the power in order to prevent further problems such as disc damage, and contact your dealer or nearest JVC service center immediately.

10-2. Error code list

Device	Device part	Error code	Description
C	U	01	UP/DOWN rotary sensor does not change
		02	Left slit sensor does not change
		03	Right slit sensor does not change
		04	UP/DOWN motor does not function
		07	UP/DOWN motor drive short-circuits and over-current is detected
		08	UP/DOWN operation exceeds the predetermined duration
		09	Lower limit sensor turn on during UP/DOWN operation
C	L	10	Tray lock release not possible
		11	Tray lock impossible, or lane change not possible
		12	Tray lock does not exist at the initial position during carrier movement
C	C	20	Catcher (right → left) movement operation exceeds the predetermined duration
		21	Catcher (left → right) movement operation exceeds the predetermined duration
		22	Catcher (right → left) convergence operation exceeds the predetermined duration
		23	Catcher (left → right) convergence operation exceeds the predetermined duration
		24	Catcher (right → left) tray rotary sensor does not change
		25	Catcher (left → right) tray rotary sensor does not change
		26	Right catcher sensor does not turn on
		27	Left catcher sensor does not turn on
		28	Catcher motor (right → left) does not function
		29	Catcher motor (left → right) does not function
		30	Tray does not exist
		31* ²	Magazine insertion incomplete, or sensor defective
C	D	41	Destination-unknown tray exists on the carrier
		42	No disc in the tray
		43	Flip tray does not exist
	F	80	During the flip raise operation, the expected time required is over
		81	During the flip descent operation, the expected time required is over
M	E	50	Mail Slot ejecting is not possible
	L	51	Mail Slot loading is not possible
	T	52	Destination-unknown tray exists in the Mail Slot
(D#)* ¹	T	60	Destination-unknown tray exists in the Drive and the control cable of the Drive is disconnected.
		61	Tray removal is not possible at the drive position
	C	62	Disc clamp of the drive does not function
	E	63	Drive ejection is not possible
	D	64	Failure to remove the disc from the drive
S	65	Spindle motor fails to stop (Ejection inhibited status)	

*1: # represents the drive number.

*2: Check the magazine loading condition. (➡ See "9-1. Ejecting/loading the magazines" on page E27.)

10-3. How to cancel the Error "64"

Please have your dealer or local JVC-authorized service agent perform this work.

Error "64" occurs when the removal of a disc from a drive fails or when the position of a disc on the tray is unstable.

During the occurrence of Error "64", even if the power is turned ON again, the unit will not startup. Perform the following operation:

- 1.** Open the door and remove the side and center panels.
 - 2.** Remove both the disc and the tray from the drive and that is on the carrier. Contact JVC for assistance.
 - 3.** Close the door, then while pressing the '0' key, turn the power ON.
- * If the cancellation of the Error "64" is performed without removing the disc and tray from the carrier, damage to either or both of them may result.

Error Codes

10-4. Error history display

The history of past errors can be displayed as described below.

1. In the normal display mode, press the MODE key.
(The menu display appears.)
2. Press the SELECT key once.
("2. ERROR DISPLAY" appears.)
3. Press the ENTER key.
(Select "2. ERROR DISPLAY".)
"NO ERROR FOUND" appears if no error has occurred in the past.
If there is any past error, the data on the latest 8 error occurrences can be recalled from memory and displayed.
4. Press the SELECT key to display the data on past errors in sequence.

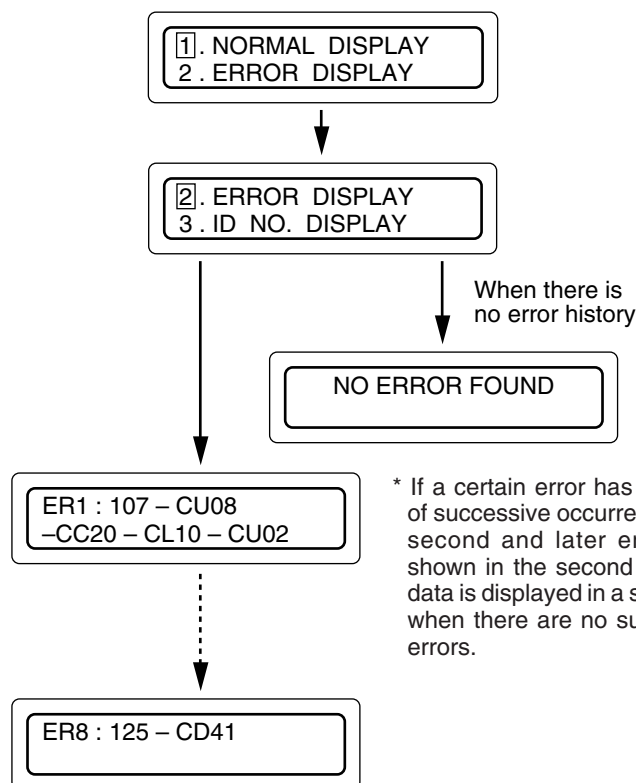
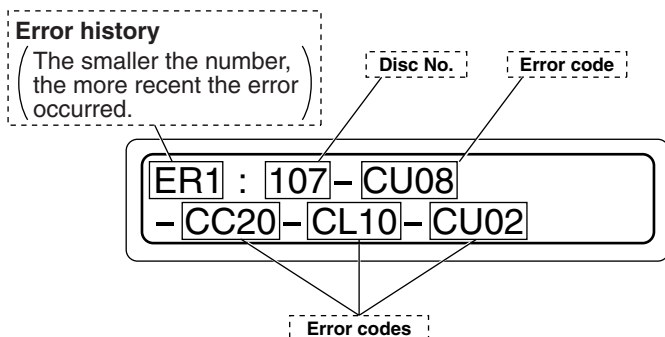

* If a certain error has a history of successive occurrences, the second and later errors are shown in the second line. The data is displayed in a single line when there are no successive errors.

- This data may be lost if the equipment is disconnected from the power source for more than six months.

10-5. Troubleshooting

When the following conditions occur, check items listed on the right.

Conditions	Causes
The changer or drives cannot be recognized by the host computer.	The host PC runs Windows 2000 as the OS and the ID No. of the Library is left to 0. (➔ P. E26)
	The SCSI cable is not an Ultra 60-compatible cable. (➔ P. E14)
	A wrong setting of the SCSI board in the host PC was made or the cable length exceeds the specific length. (➔ P. E14)
	The drive unit SCSI connector is improperly connected. (➔ P. E23)
	The drive unit power cable is improperly connected. (➔ P. E23)
	Overlapping of the SCSI-ID Nos. has occurred. (➔ P. E15, E23)
The drive is identified but a disc cannot be transported to the drive.	The drive unit control cable is improperly connected. (➔ P. E15, E23)
Read (write) errors occur.	The disc is either dirty or damaged. (➔ P. E5)
	The SCSI cable is not an Ultra 60-compatible cable. (➔ P. E14)
	A wrong setting of the SCSI board in the host PC was made or the cable length exceeds the specific length. (➔ P. E14)
	The drive unit control cable is improperly connected. (➔ P. E23)
The initial setup of the SCSI device is not possible using a driver software.	SCSI ID Nos. are conflicting. (➔ P. E14, E23)
The LCD display shows "UNKNOWN DRIVE TYPE DETECTED".	The drive detection mode has not been executed. (➔ P. E25)

11. ACCESS COUNTS

Access counts of the main unit (changer) and each unit (carrier, drives 1 - 6 and color disc printer) can be checked using this function.

1. In the normal display mode, press the MODE switch.
(The menu display appears.)
2. Press the SELECT key 6 times.
("7. COUNT DISPLAY" appears.)
3. Press the ENTER key.
(Select "7. COUNT DISPLAY".)

```

1 . NORMAL DISPLAY
2 . ERROR DISPLAY
    
```

```

7 . COUNT DISPLAY
8 . IMPORT / EXPORT
    
```

4. Pressing the SELECT key changes the display.

1. TOTAL : The total access count for the Library.
2. CR : Carrier
3. MS : Mail slot
4. DR1 : Drive 1
5. DR2 : Drive 2
6. DR3 : Drive 3
7. DR4 : Drive 4
8. DR5 : Drive 5
9. DR6 : Drive 6
10. FL : Flip
(Only when the MC-CF10U Optional Carrier is installed)

```

1 . TOTAL : 000237
2 . CR : 000179
    
```

```

2 . CR : 000179
3 . MS : 000020
    
```

SELECT

```

9 . DR6 : 000004
1 . TOTAL : 000237
    
```

SELECT

```

1 . TOTAL : 000237
2 . CR : 000179
    
```

SELECT

- Access counts of unconnected drive units will appear as[-----].
- The initial "TOTAL" access count from the factory may be "999880-999999".
- This data may be lost if the equipment is disconnected from the power source for more than six months.

SPECIFICATIONS

Item	MC-8200LU	MC-8600LU		
Number of stored discs	200	600		
Number of magazines	4	12		
Operating environment	Temperature: 5°C to 35°C (41°F to 95°F) (Note 1) Humidity: 10% to 80% (no condensation)			
Rated power voltage	AC 120 V to 240 V			
Rated power frequency	50 Hz/60 Hz			
Rated current	2.4 A to 1.4 A (max. value), 1.4 A to 0.8 A (6 Drives are loaded)	3.2 A to 1.8 A (max. value), 1.4 A to 0.8 A (6 Drives are loaded)		
Power consumption	140 W (Reference value, 6 DVD-RAM drives are loaded)			
Interface	68-pin external SCSI connector			
Drive slots rack bays	6			
Media size	12 cm discs			
Applicable options	Drives	Available drives	Compatible discs	
		DVD-RAM/R drive	MC-R434U	Write/Read Read
	<ul style="list-style-type: none"> The relevant specifications for the drives can be found in the appropriate instruction manual. Concerning the Availability/Compatibility of the drives that are not listed, please contact your dealer or nearest JVC service centre. The production of a particular drive may be discontinued without prior notice. Therefore, a replacement drive may be changed to a different model. JVC does not provide a warranty in the case of software not functioning correctly as a result of a drive being replaced or added. 			
	Carrier	Single-sided / Double-sided compatible disc carrier: MC-CF10U		
Magazine	Magazine set: MC-M25U (B)			
Weight	58kg (Excluding the discs and optional equipment)	104kg (Excluding the discs and optional equipment)		

Dimensions (Unit: mm)

MC-8200LU

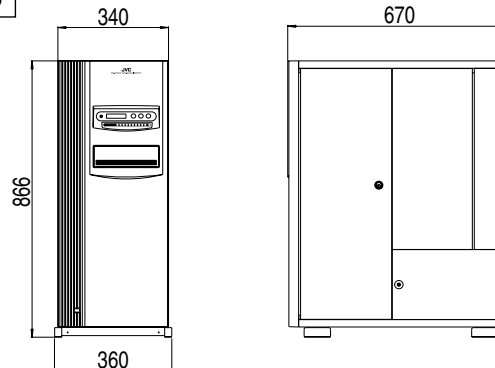

MC-8600LU

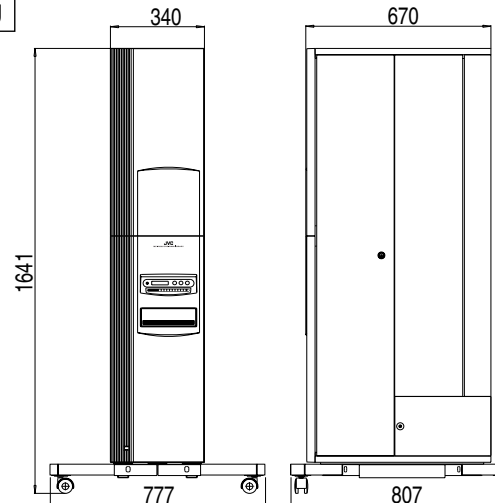

View when the door is open (Top view)

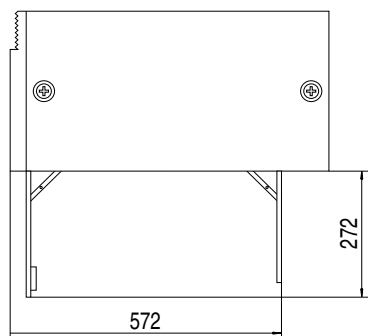

Design and specifications are subject to change without notice.

Note 1 : When using 6 of the MC-R434U units together, be sure that the room temperature is between 5 °C and 30 °C.



JVC[®] is a registered Trademark owned by VICTOR COMPANY OF JAPAN, LTD.

JVC[®] is a registered Trademark in Japan, the U.S.A., the U.K. and many other countries.